

CITY OF RICHMOND, VIRGINIA

DEPARTMENT OF PUBLIC WORKS

TRANSPORTATION ENGINEERING DIVISION

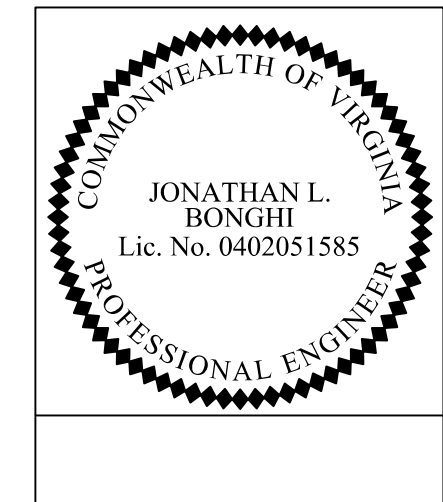

Bike Infrastructure / Roadway Conversion Project

Belmont Road Bike Lanes

Chippenham Parkway To Walmsley Boulevard

CITY PROJECT NO. , AWARD NO.

INDEX OF SHEETS	
Sheet Title	Sheet No.
TITLE SHEET & INDEX OF SHEETS	1
GENERAL NOTES	1A
PROPOSED SIGN SCHEDULE	1B
DETAILS	1C
EXISTING CONDITIONS PLAN	2-6
PROPOSED SIGNAGE AND STRIPING PLAN	7-11

- NOTES:
- ALL WORK IS WITHIN THE EXISTING RIGHT OF WAY.
 - DESIGN FEATURES RELATING TO CONSTRUCTION OR TO REGULATION AND CONTROL OF TRAFFIC MAY BE SUBJECT TO CHANGE AS DEEMED NECESSARY BY THE CITY OF RICHMOND.
 - THIS PROJECT IS TO BE CONSTRUCTED IN ACCORDANCE WITH THE 2016 VDOT ROAD AND BRIDGE SPECIFICATIONS, 2016 VDOT ROAD AND BRIDGE STANDARDS, 2009 FHWA MANUAL ON UNIFORM TRAFFIC CONTROL DEVICES (MUTCD), 2011 VIRGINIA SUPPLEMENT TO THE MUTCD, 2011 VIRGINIA WORK AREA PROTECTION MANUAL, APPLICABLE CITY OF RICHMOND STANDARDS AND SPECIFICATIONS, AND AS AMENDED BY CONTRACT PROVISIONS AND THE COMPLETE ELECTRONIC VERSION OF THE PLAN ASSEMBLY.
 - PROJECT BASE MAPPING WAS OBTAINED FROM THE CITY OF RICHMOND GIS WEBSITE AND WAS NOT FIELD SURVEYED TO VERIFY ACCURACY. CONTRACTOR SHALL FIELD VERIFY WIDTHS PRIOR TO INSTALLATION OF PROPOSED PAVEMENT MARKINGS.

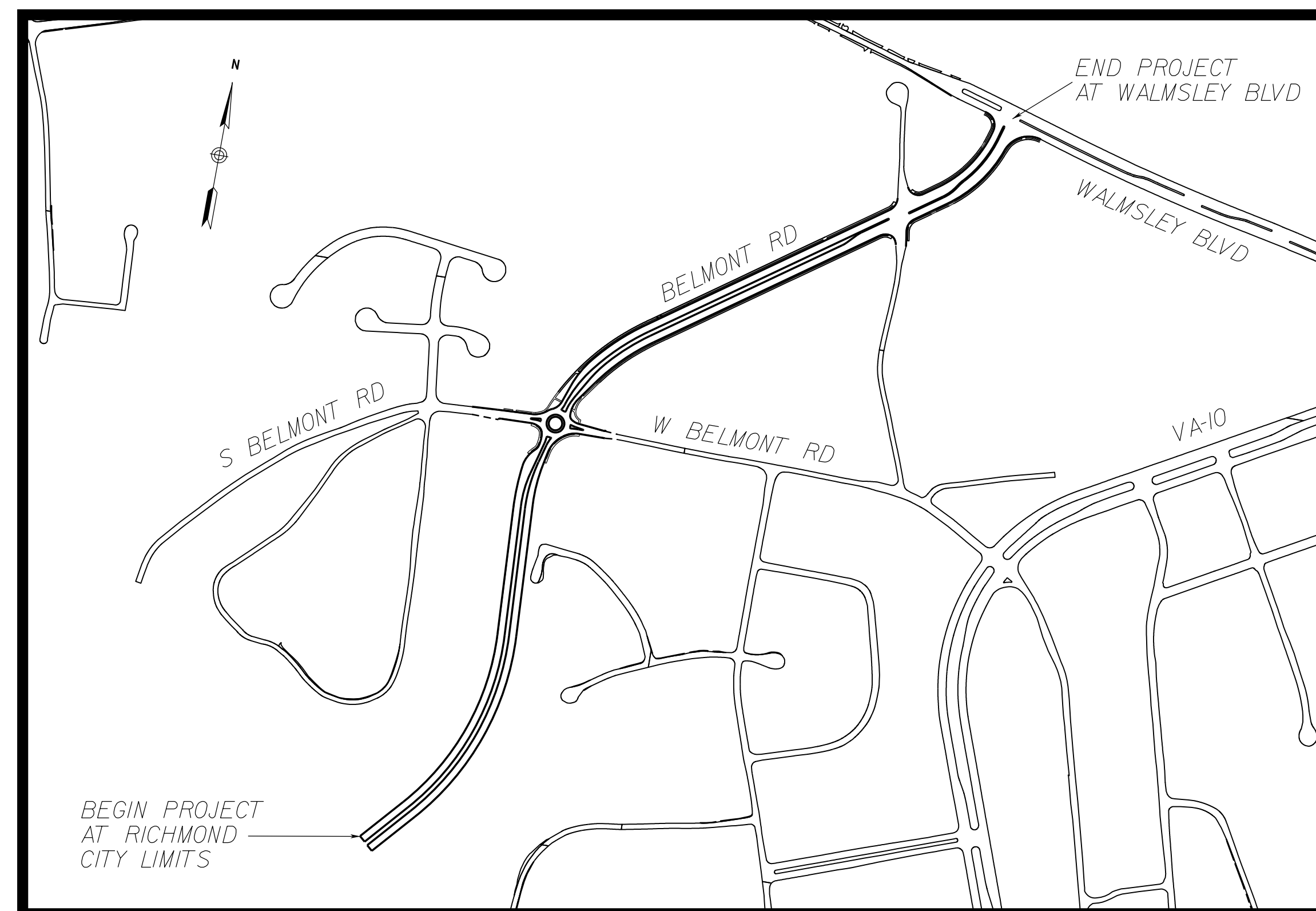

CITY OF RICHMOND
DEPT. OF PUBLIC WORKS
RICHMOND, VA

LOCATION MAP
NTS
August 2020

CITY OF RICHMOND	
APPROVED FOR CONSTRUCTION	
DATE	SURVEYS SUPERINTENDENT
DATE	PROJECT MANAGER
DATE	MAINTENANCE ENGINEER
DATE	CITY TRANSPORTATION ENGINEER
DATE	CAPITAL PROJECTS ADMINISTRATOR
DATE	CITY ENGINEER
DATE	DIRECTOR OF PUBLIC WORKS

REVISIONS		
NO.	DATE	COMMENTS

Drawing No.



GENERAL NOTES

- 1. The Contractor shall be responsible for ensuring that all utilities within the project limits are identified and located before beginning work. The Contractor shall contact Miss Utility of Virginia at 1-800-522-7001, 48 hours prior to any construction activities. Contractor shall coordinate with utility companies as to the location of existing and approved plans of future utility lines. Any disruption of any utility service is the solely the responsibility of the Contractor.
- 2. All work shall be in accordance with the current edition of the Manual of Uniform Traffic Control Devices (MUTCD), The Virginia Supplement to the MUTCD, and all City of Richmond special provisions, and specifications in effect at the time these plans are approved.
- 3. Any pavement markings that will conflict with the proposed pavement markings shall be completely eradicated.
- 4. The contractor shall be responsible for job site security and safety. Construction activities shall be in accordance with OSHA and local requirements.
- 5. Work shall remain within the existing right of way and shall conform to the City of Richmond Standards.
- 6. Contractor shall make necessary construction notifications and apply for and obtain all necessary permits and post any bonds associated with the work indicated on these plans. Contractor shall not close or obstruct any existing roadways, sidewalks, or fire hydrants without obtaining the appropriate permit from the City.
- 7. Contractor shall dispose of demolition debris and salvage materials in accordance with applicable Federal, State, and Local regulations, statutes, and ordnances.
- 8. Areas outside the limits of the proposed work, which are disturbed by the Contractor's activities, shall be restored back to their original condition by the contractor at the contractor's expense.
- 9. This project is not subject to The City of Richmond stormwater management permit (RSMP), as land disturbance is less than 2500 SF.
- 10. Contractor shall phase work to minimize time between the removal of the existing pavement markings and traffic control devices and the installation of the proposed pavement markings and traffic control devices.
- 11. Contractor shall seal all asphalt and repair surface as necessary, along bike lanes where minor cracks or joints impede normal bicycle flow. Larger surface repairs or land disturbance activities, if required shall be performed under a separate contract. Notify city engineer of surface conditions where major pavement repairs may be required.
- 12. Prior to completing pavement marking operations the contractor shall inspect the existing side street stop bars to ensure they are complete and visible. If an existing side street stop bar shows signs of excessive wear or is missing portions of the complete marking, the stop bar shall be replaced in its entirety.
- 13. All utility poles and signal poles are to remain along the project corridor and shall be protected during construction. If pole-mounted signs are shown to be removed or replaced with a new sign panel, care shall be taken to protect the pole during sign removals and installations.

LAYOUT AND MATERIALS

- 1. Dimensions are from the face of curb and to the centerline of pavement markings, unless otherwise noted.
- 2. Proposed bounds and any existing property line monumentation disturbed during construction shall be set or reset by a professional licensed surveyor.
- 3. When necessary, existing sidewalk shall be saw cut leaving a smooth squared opening for the installation of proposed sign structures. Upon completion of sign structure installation, the existing sidewalk shall be patched/repared with a minimum of 3000 psi concrete. No additional concrete repair is anticipated with this project, however any incidental concrete for repair or replacement of existing conditions shall be a minimum of 3000 psi.
- 4. The vertical flexible delineators shown on these plans shall be the PEXCO FG300 MODEL UR or equivalent if approved as equal. The proposed vertical flexible delineators shall be approved by the City of Richmond project manager prior to ordering materials.

EXISTING CONDITIONS INFORMATION

- 1. PROJECT BACKGROUND/BASE PLAN: The property lines and any other existing conditions and features shown are based on information compiled from the City of Richmond GIS and aerial photography. The information shown is not warranted to be exact or complete. Field verifications of pavement widths, existing pavement markings, and sign locations were performed by VHB in May 2020. Contractor shall notify the Engineer immediately if site conditions shown differ from those shown on these plans.

MAINTENANCE OF TRAFFIC

The purpose of these notes are to describe general traffic operations during construction and it is not intended to provide all necessary details related to maintenance of traffic.

- 1. All maintenance of traffic operations and materials shall meet the requirements of the current edition of the Virginia Work Area Protection Manual (VA WAPM), the 2009 MUTCD and any revisions to these documents at the time these plans were approved.
- 2. Construction warning signs shall be placed in the advanced warning area and "End Road Work" signs shall be placed at the end of the project area in accordance with the VA WAPM. Contractor shall provide all necessary signs and sign stands or posts, which allow for an unrestricted view of the sign message for all project warning and regulatory signs during construction.
- 3. Construction is allowed Monday through Saturday during the contract period. No lane restrictions or closures will be allowed on Sundays unless directed by the City of Richmond Transportation Engineer.
- 4. No temporary lane closures, restrictions or flagging operations are permitted along any project roadway between the hours of 6:00AM and 9:00AM and the hours of 3:30PM and 6:00PM Monday through Friday, or as directed by the project engineer.
- 5. Lane closures will not be permitted on Holidays or on the day before or the day after a holiday unless otherwise directed by the City of Richmond Transportation Engineer.
- 6. Contractor shall submit a Maintenance of Traffic Plan to the city Traffic Engineer for review and approval, a minimum of two weeks in advance of the beginning of construction.
- 7. Contractor shall maintain safe access to all existing driveways and maintain pedestrian access along the project corridor at all times.
- 8. Any work activities within 15 feet of the travel way shall be signed accordingly. Under no circumstance shall work be performed concurrently on both the left and right side of any travel lane.
- 9. No temporary traffic control measures will be allowed to be placed within the right of way prior to the start of construction.
- 10. Any flaggers used during construction shall be state certified. Certification shall be available on site at all times.
- 11. Signing, marking, and other traffic control measures may be changed or adjusted during the course of the project when deemed necessary by the City in the best interest of the general public and to ensure the safe and orderly flow of traffic.
- 12. Failure to provide temporary traffic control devices in accordance with the VA WAPM shall result in immediate corrective measures by the contractor at no additional cost to the city. All traffic devices and temporary signs shall be clean, legible and in fully functional condition.

CITY OF RICHMOND DPW - (WORK WITHIN ROW)

- 1. All work in the streets and sidewalks shall be performed under an approved permit and monitored by the permit inspector assigned to the project.
- 2. Work shall not commence until the permit inspector has been notified, a pre-construction conference is held and Miss Utility has cleared the project.
- 3. Any disturbed sidewalk or curb within the project limits shall be repaired and replaced in accordance with the City of Richmond Standards and as shown in these plans.

DOCUMENT USE

- 1. These plans and corresponding CADD documents are instruments of professional service and shall not be used, in whole or in part, for any purpose other than for which it was created without the expressed, written consent of VHB. Any unauthorized use, reuse, modification or alteration, including automated conversion of this document shall be at the user's sole risk without liability or legal exposure to VHB.
- 2. Contractor shall not rely solely on electronic versions of the plans, specifications, and data files that are obtained from the designer, but shall verify location of project features in accordance with the paper copies of the plans and specifications that are supplied as part of the contract documents.
- 3. Symbols and legends of project features are graphic representations and are not necessarily scaled to their actual dimensions or exact locations on the drawings. The contractor shall refer to the detail sheet dimensions, the manufacturer's literature, shop drawings and field measurements of the supplied products for layout and installation of the project features.



115 South 15th Street
Suite 200
Richmond, VA 23219
804.343.7100

Bike Infrastructure / Roadway Conversion Project
Belmont Road
Richmond, Virginia

No.	Revision	Date	Apprv.

Designed by: SCN Checked by: JLB
Issued for: 90% Construction Plan Date: August 2020

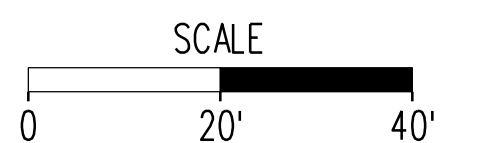

Drawing Title
General Notes

PROJECT	SHEET NO. /A
---------	--------------



SIGN SCHEDULE

SIGN ASSEMBLY NO(s).	TEXT	SIGN ASSEMBLY COMPONENTS				SIGN PANEL AREA (S.F.)		SIGN STRUCTURE ST'D.	REMARKS
		MUTCD ST'D.	PANEL SIZE		QTY.	per Sign	per Assembly		
			W	H					
101		I-18	Exist.	Exist.	1	4.5	10.5	Existing	EXISTING SIGN TO REMAIN IN PLACE
		N/A	Exist.	Exist.	1	6.0			RELOCATE SIGN FROM UTILITY POLE (LOCATION 102) TO LOCATION 101
102		W4-2	36	36	1	9.0	9.0	Existing	RELOCATED SIGN, MOUNT TO EXISTING UTILITY POLE AT LOCATION 102
103, 106, 109, 110		R3-17	24"	18"	1	3.0	5.0	STP-1, 2" - 14 GA	FOUNDATION - TYPE D
		R3-17bP	24"	12"	1	2.0			
104		R3-17	24"	18"	1	3.0	5.0	STP-1, 2" - 14 GA	FOUNDATION - TYPE D
		R3-17aP	24"	12"	1	2.0			
105, 107, 108, 111		M4-14	24"	12"	1	2.0	5.0	STP-1, 2" - 14 GA	FOUNDATION - TYPE D
		R3-17	24"	18"	1	3.0			

NOTES:

- 1) ALL SIGNS SHALL BE ORIENTATED AS SHOWN ON THE PLANS.
- 2) SIGN COLOR COMBINATIONS SHALL BE IN ACCORDANCE WITH THE FHWA STANDARD HIGHWAY SIGNS BOOK AND THE 2011 VIRGINIA STANDARD HIGHWAY SIGNS BOOK OR AS NOTED IN THE PLANS.
- 3) ALL ST'D.STP-1 STRUCTURES TO BE SINGLE POST UNLESS OTHERWISE NOTED.



115 South 15th Street
Suite 200
Richmond, VA 23219
804.343.7100

Bike Infrastructure / Roadway Conversion Project
Belmont Road
Richmond, Virginia

No. Revision Date Apprd.

Designed by **SCN** Checked by **JLB**

Issued for _____ Date _____

90% Construction Plan August 2020

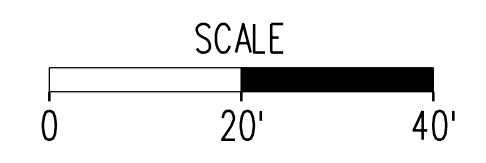

Drawing Title
Proposed Sign Schedule

PROJECT	SHEET NO.
	18

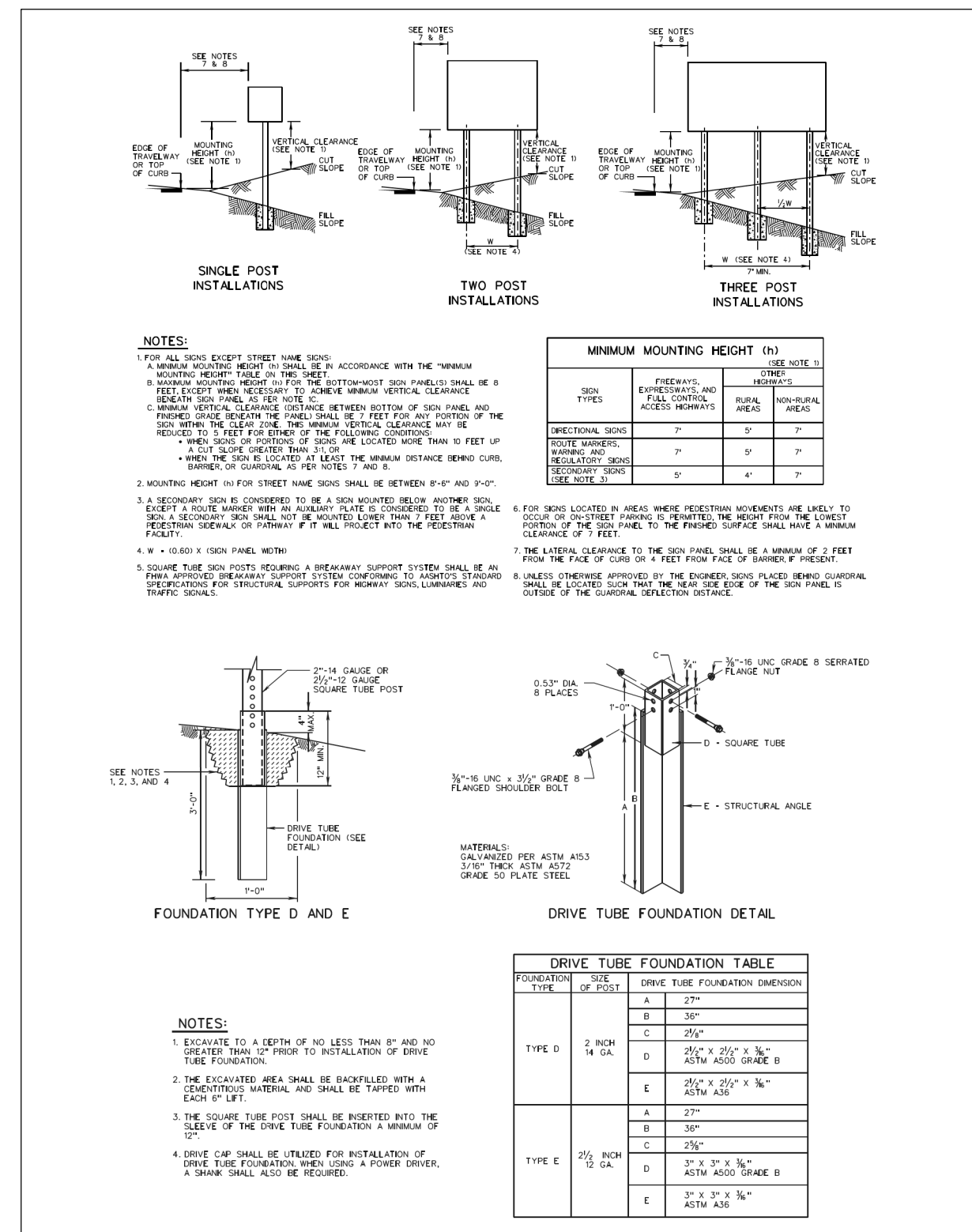

Sign Post - VDOT STP-1 and Type-D & E Foundation
Source: VDOT 1321.10 & 1321.17

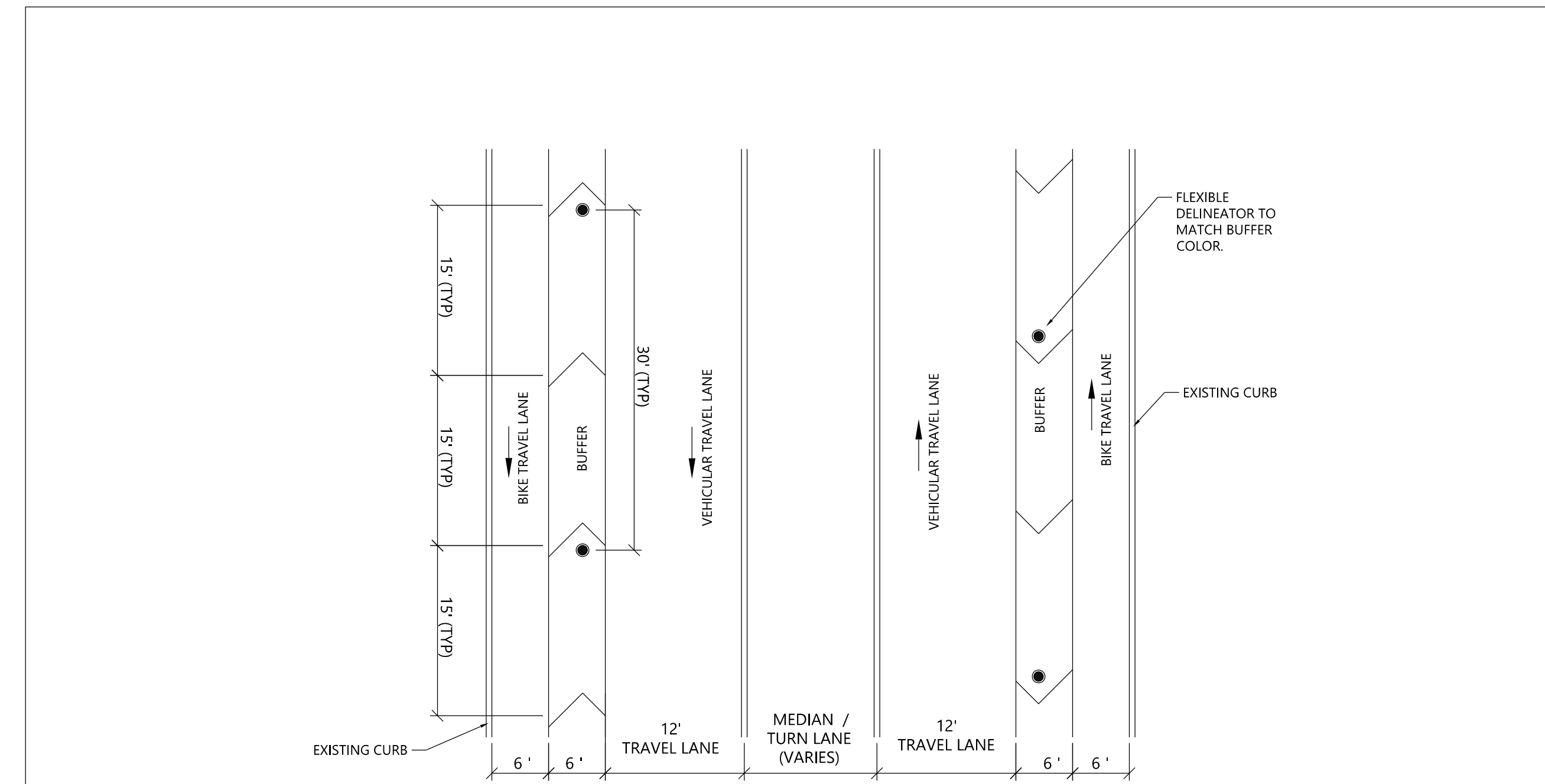

Typical Roadway Dimensions and Section
N.T.S. Source: VHB

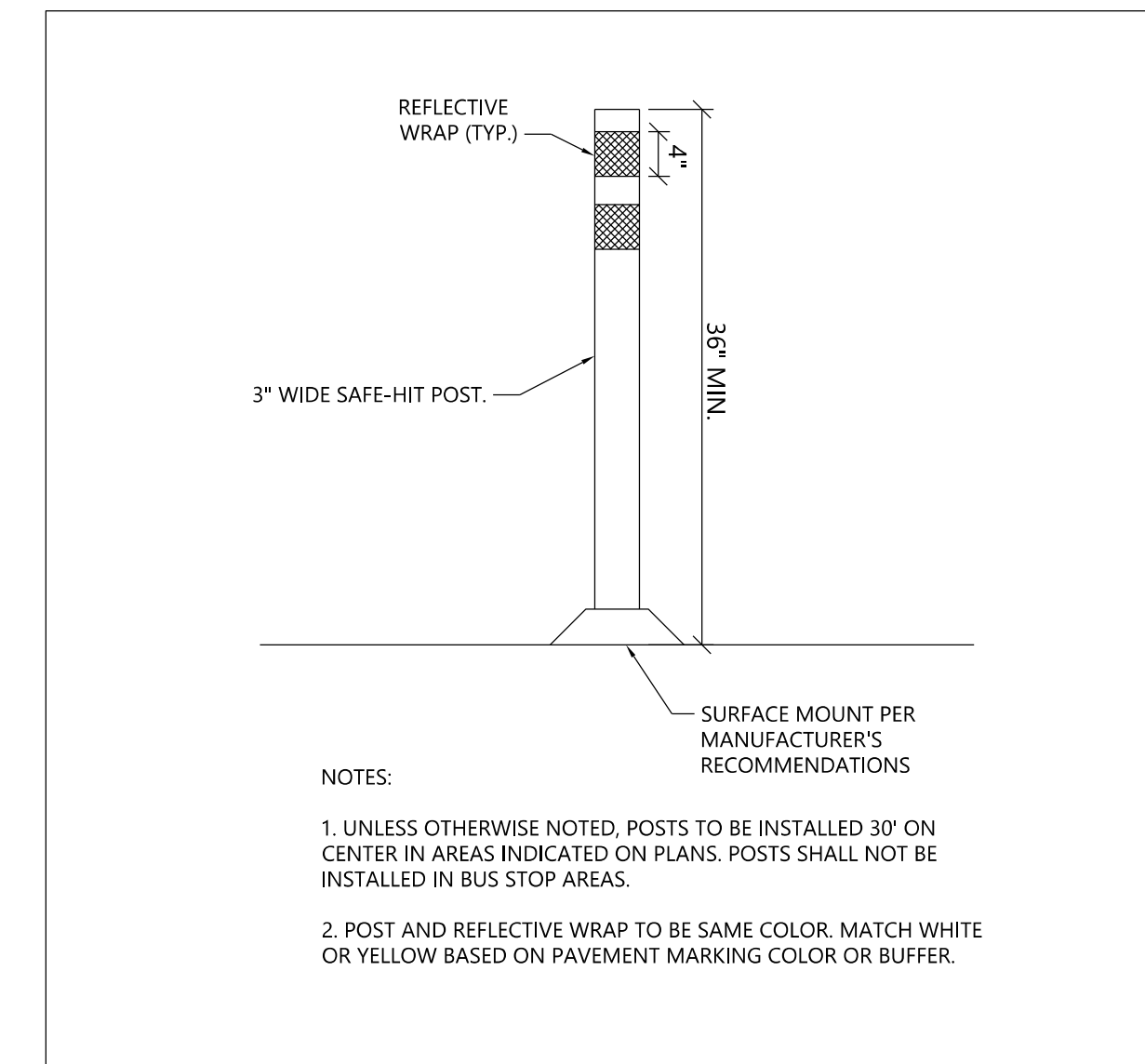

Vertical Flexible Delineator
N.T.S.

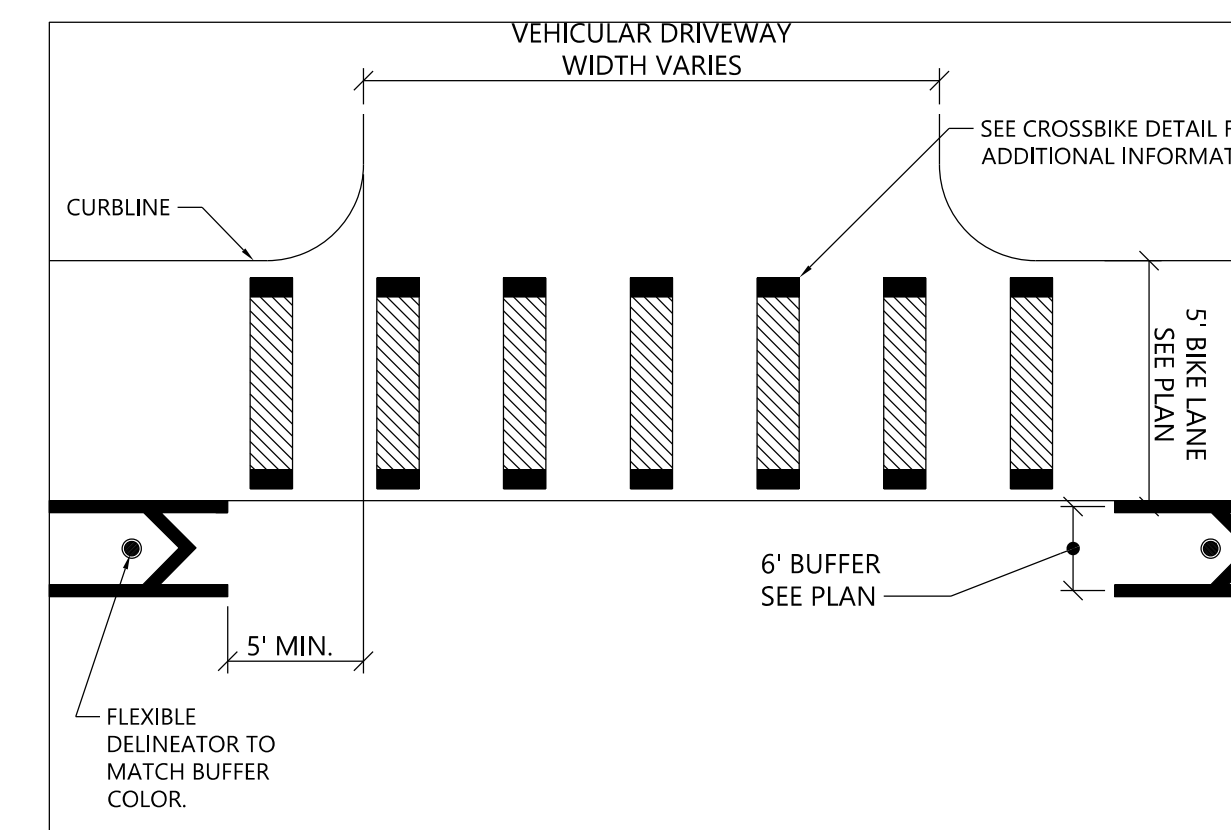

Bike Lane Street Crossing
N.T.S. Source: VHB

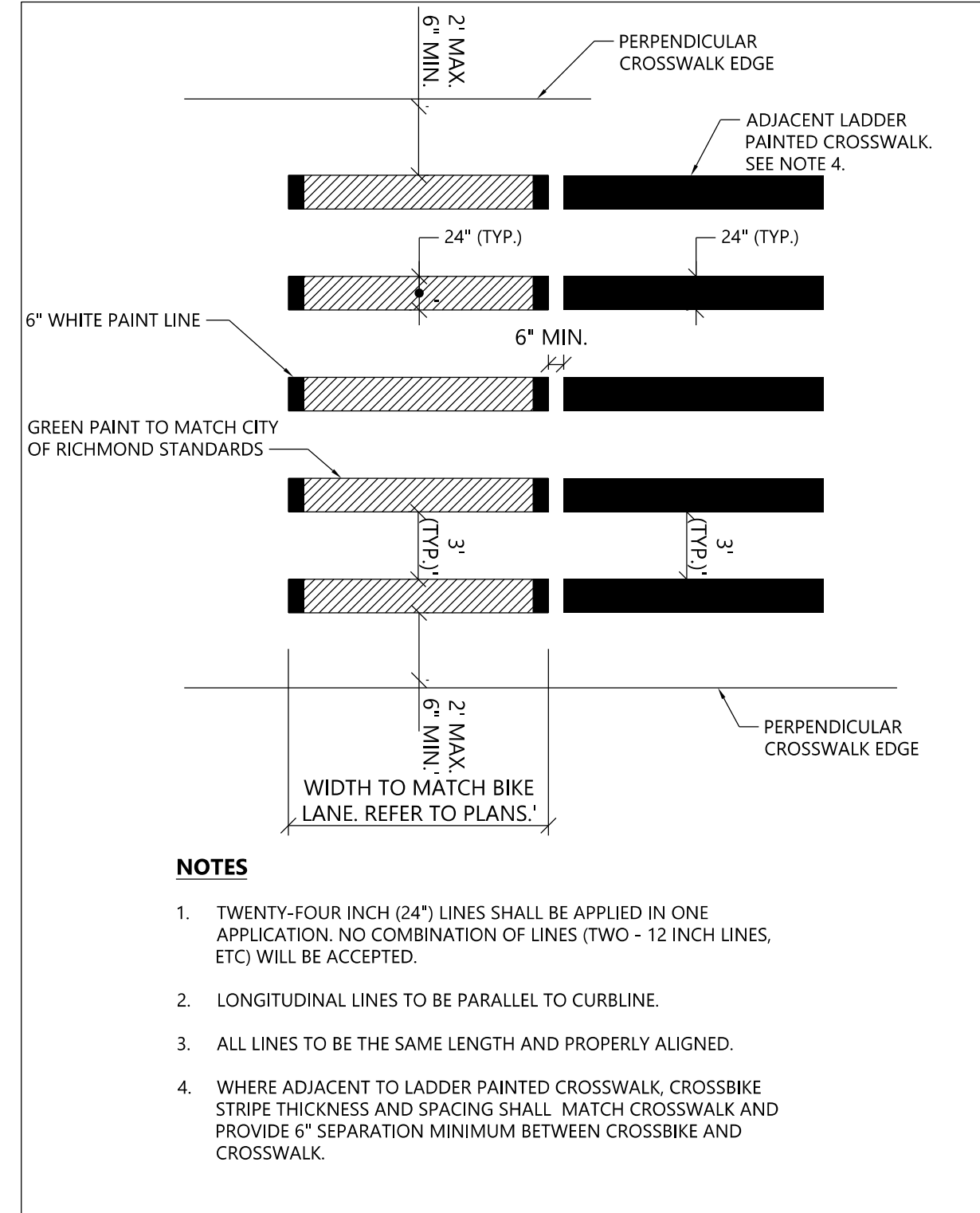

Crossbike
N.T.S. Source: VHB

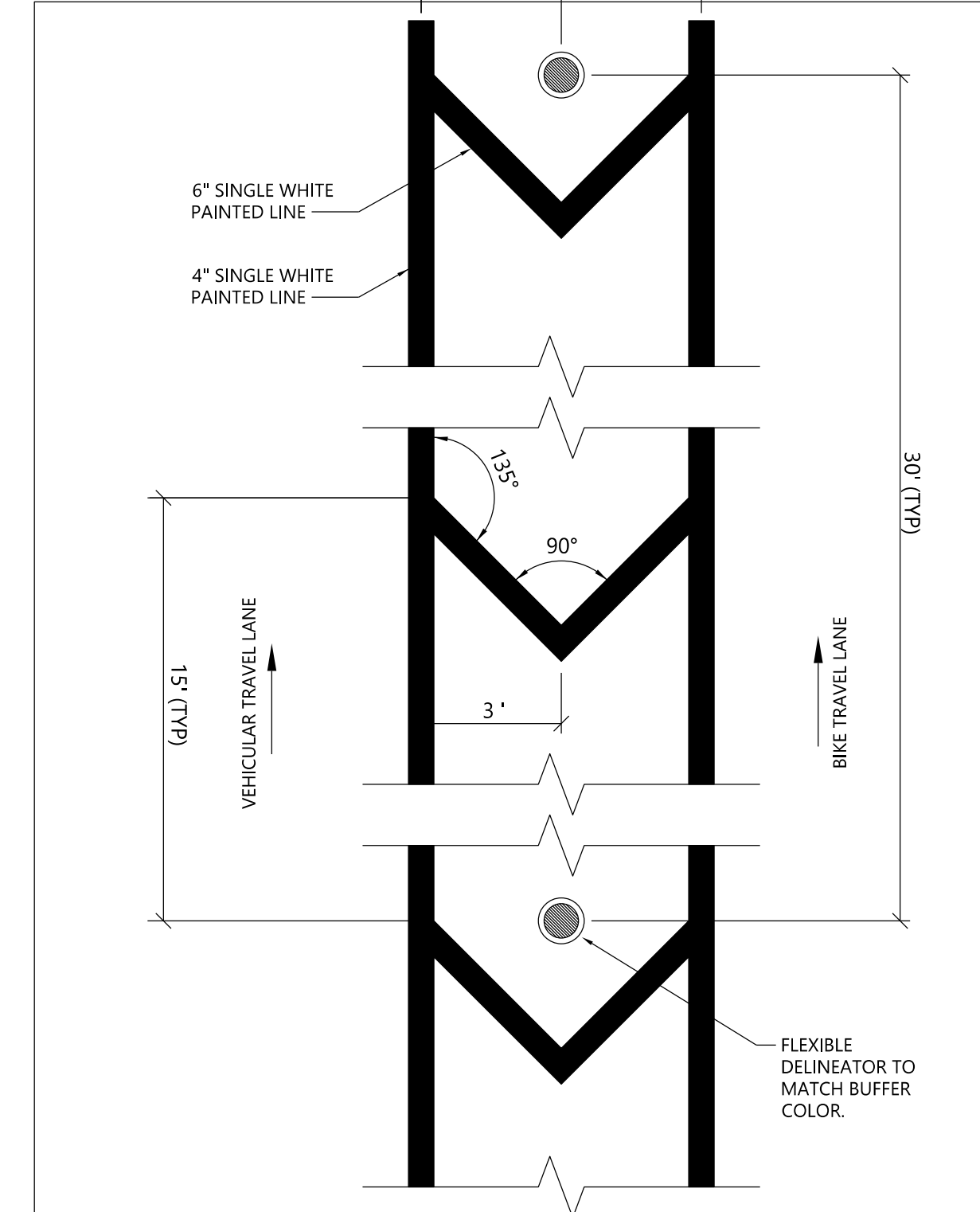

Bike Lane Buffer Striping
N.T.S. Source: VHB

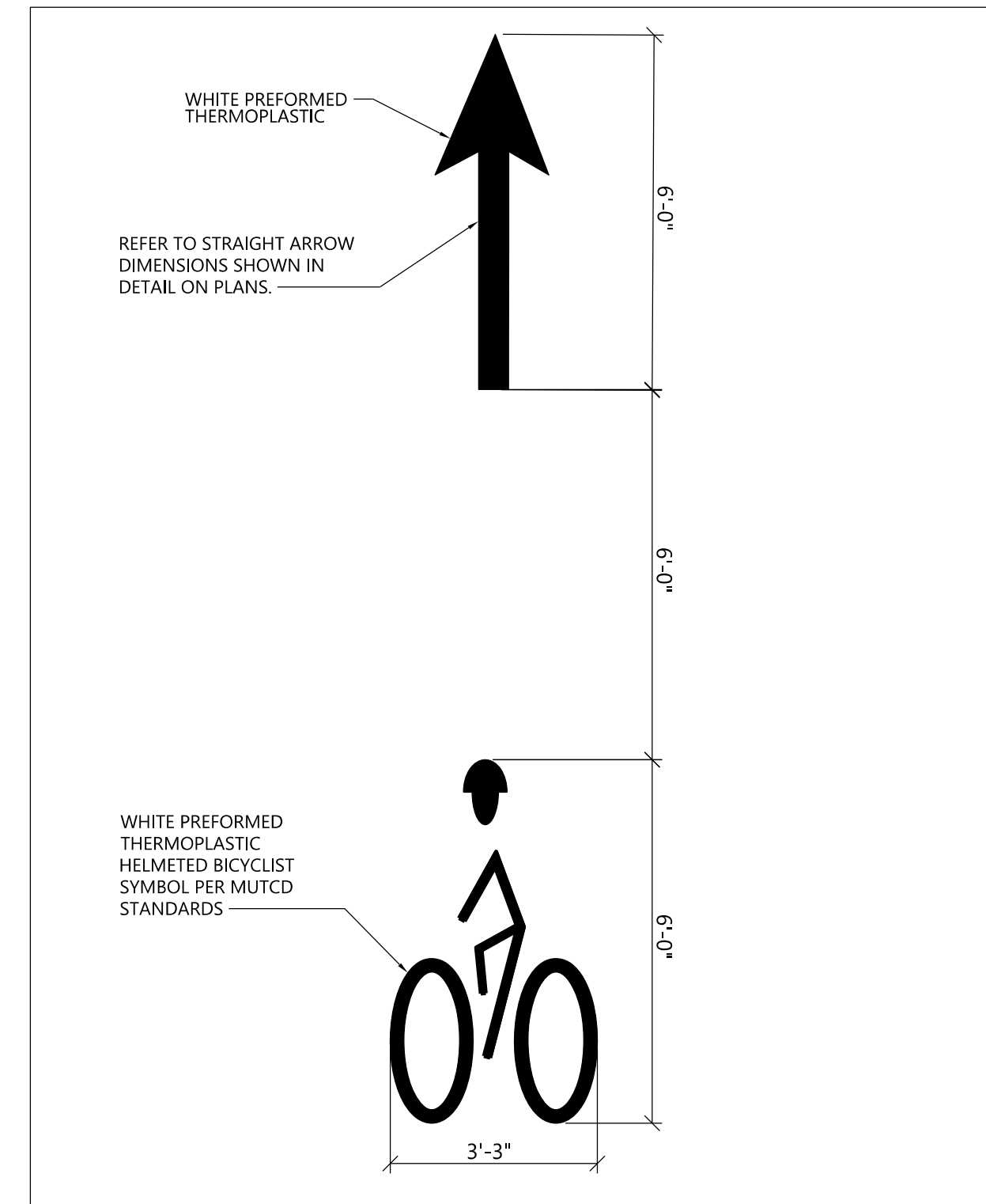

Helmeted Bicyclist and Arrow
N.T.S. Source: VHB

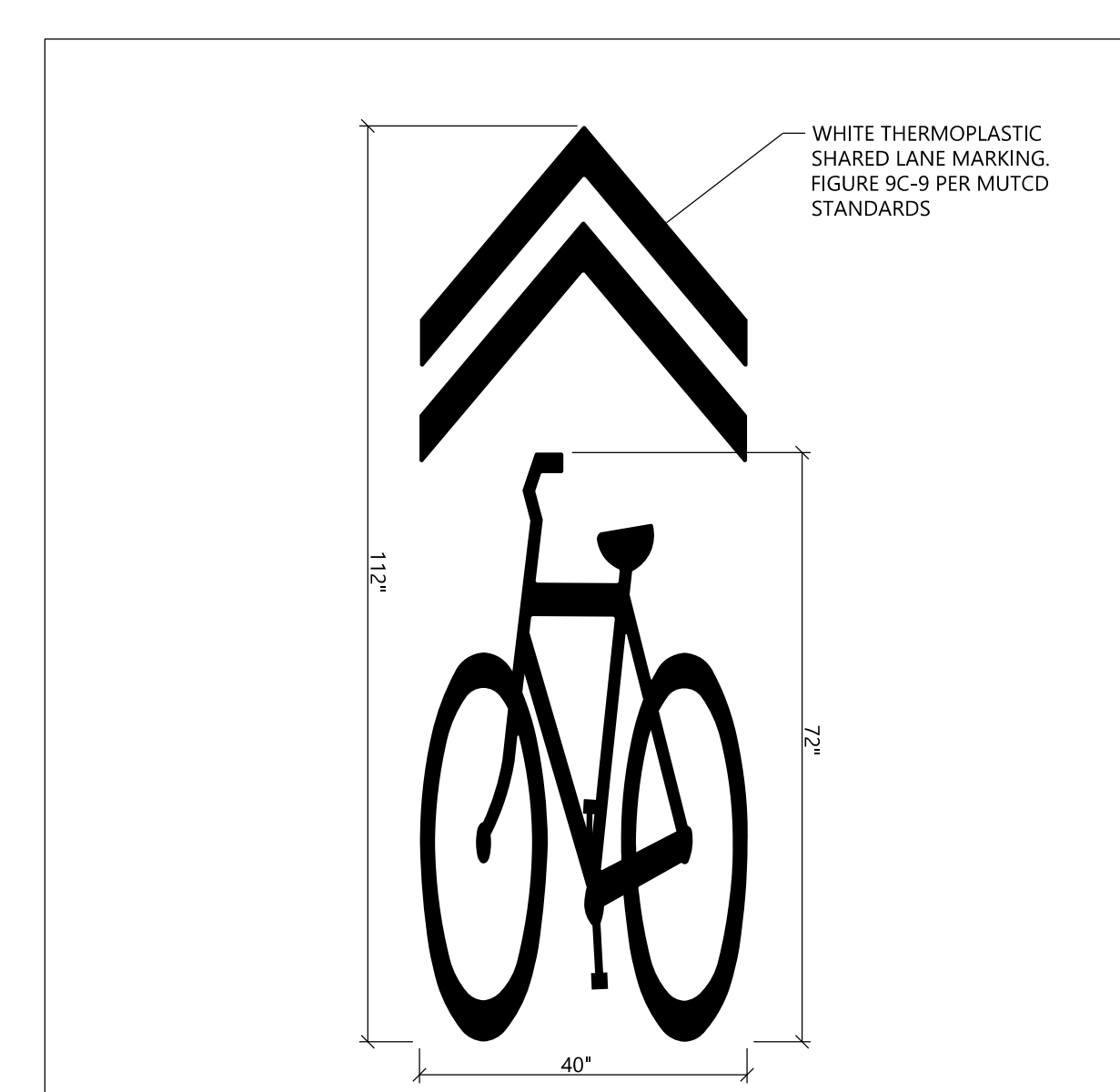

Shared Lane Marking
N.T.S. Source: VHB



115 South 15th Street
Suite 200
Richmond, VA 23219
804.343.7100

Bike Infrastructure / Roadway Conversion Project
Belmont Road
Richmond, Virginia

No.	Revision	Date	Apprv.

Designed by **SCN** Checked by **JLB**
Issued for **90% Construction Plan** Date: **August 2020**

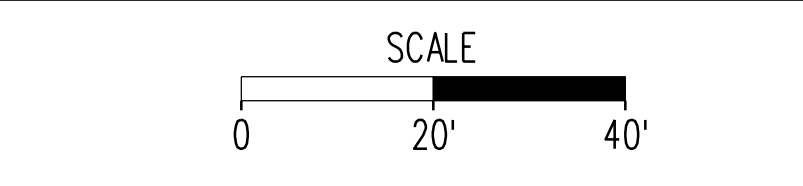

Drawing Title

Details

PROJECT	SHEET NO. 1C
---------	------------------------



115 South 15th Street
Suite 200
Richmond, VA 23219
804.343.7100

**Bike Infrastructure /
Roadway Conversion Project**
Belmont Road
Richmond, Virginia

No.	Revision	Date	Appvd.

Designed by **SCN** Checked by **JLB**
Issued for **90% Construction Plan** Date **August 2020**

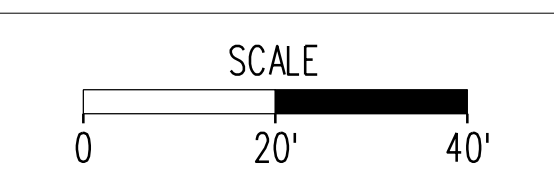

Drawing Title
Existing Conditions

PROJECT	SHEET NO.
	2

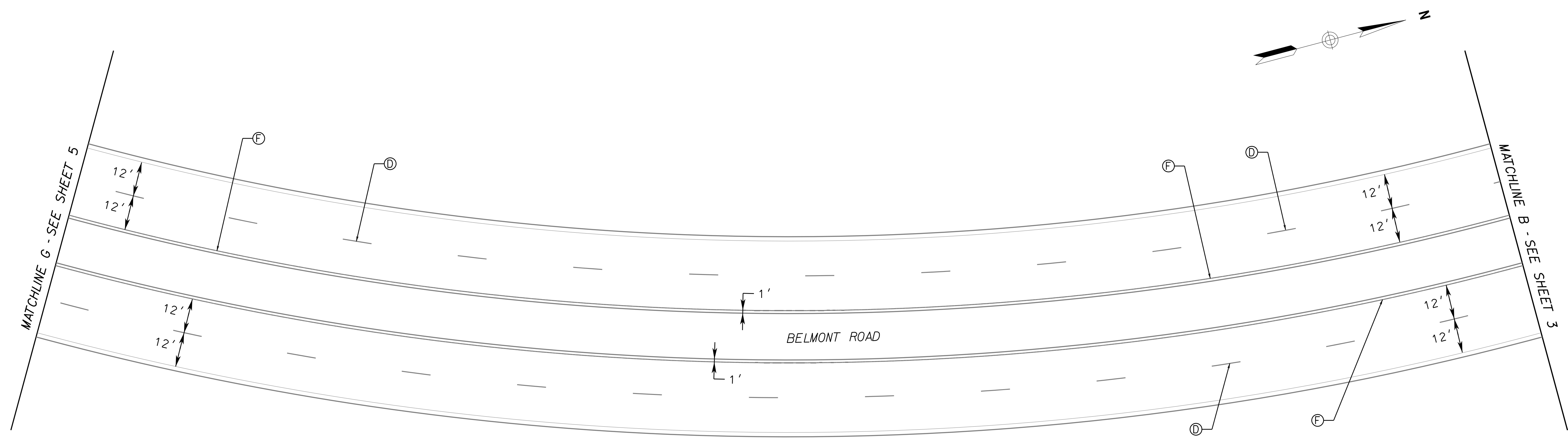
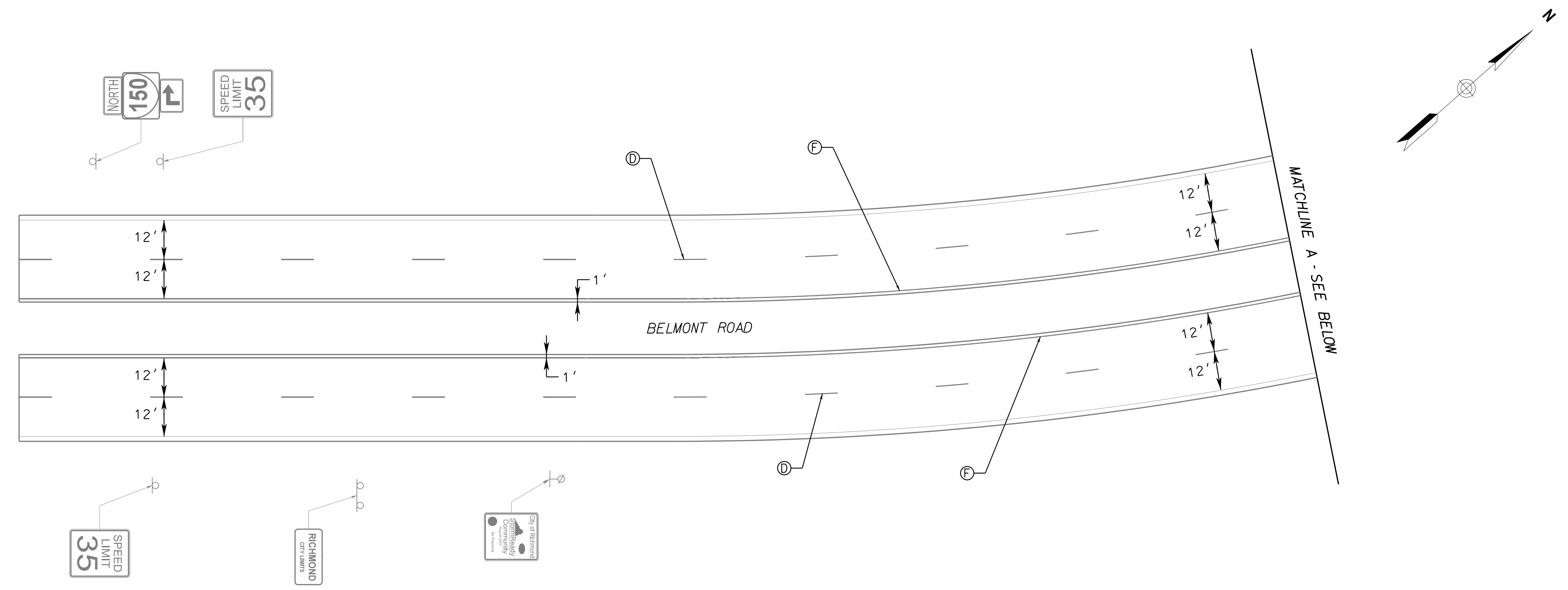

EXISTING PAVEMENT MARKINGS LEGEND

- (A) EXISTING. 24" WHITE STOPBAR
- (B) EXISTING. 24" WHITE DIAGONAL CROSS HATCH
- (C) EXISTING. 4" SOLID WHITE
- (D) EXISTING. 4" WHITE, 10' LONG, 30' SPACE
- (E) EXISTING. 4" WHITE, 2' LONG, 4' SPACE
- (F) EXISTING. 4" SOLID YELLOW
- (G) EXISTING. 4" DOUBLE YELLOW LINE
- (H) EXISTING. 8" WHITE, 3' LONG, 3' SPACE
- (I) EXISTING. PAVEMENT MARKING ELONGATED ARROW, SINGLE (RIGHT)
- (J) EXISTING. PAVEMENT MARKING ELONGATED ARROW, SINGLE (LEFT)
- (K) EXISTING. PAVEMENT MARKING YIELD TRIANGLE
- (L) EXISTING. PAVEMENT MARKING MERGE ARROW

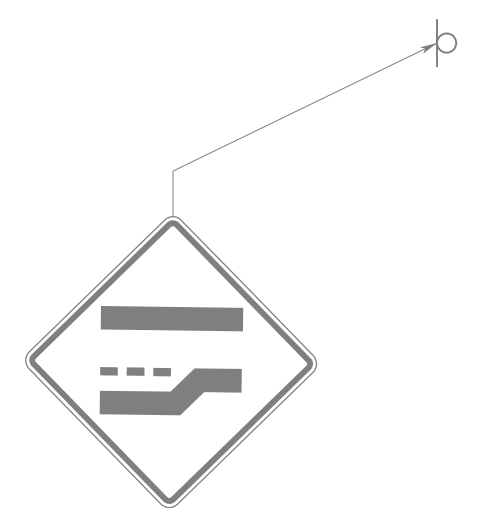

8/13/2020 10:49:28 AM

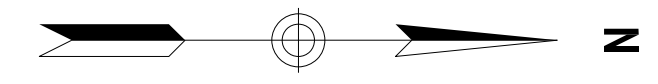

115 South 15th Street
Suite 200
Richmond, VA 23219
804.343.7100

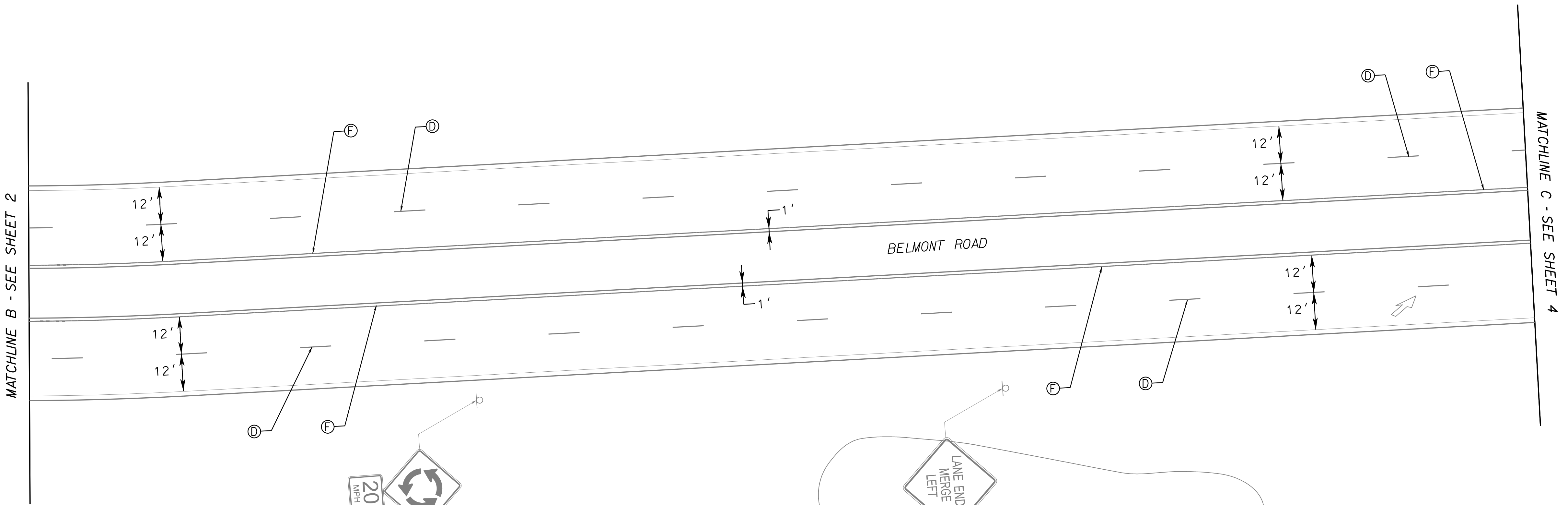

Bike Infrastructure / Roadway Conversion Project

Belmont Road
Richmond, Virginia

No.	Revision	Date	Apprv.

Designed by **SCN** Checked by **JLB**

Issued for **90% Construction Plan** Date **August 2020**

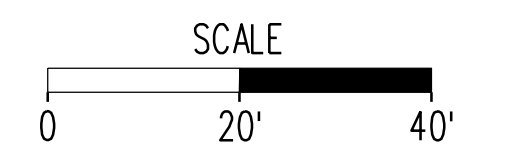

Drawing Title

Existing Conditions

PROJECT	SHEET NO.
	3

EXISTING PAVEMENT MARKINGS LEGEND

- | | |
|--|--|
| (A) EXISTING, 24" WHITE STOPBAR | (I) EXISTING, PAVEMENT MARKING ELONGATED ARROW, SINGLE (RIGHT) |
| (B) EXISTING, 24" WHITE DIAGONAL CROSS HATCH | (J) EXISTING, PAVEMENT MARKING ELONGATED ARROW, SINGLE (LEFT) |
| (C) EXISTING, 4" SOLID WHITE | (K) EXISTING, PAVEMENT MARKING YIELD TRIANGLE |
| (D) EXISTING, 4" WHITE, 10' LONG, 30' SPACE | (L) EXISTING, PAVEMENT MARKING MERGE ARROW |
| (E) EXISTING, 4" WHITE, 2' LONG, 4' SPACE | |
| (F) EXISTING, 4" SOLID YELLOW | |
| (G) EXISTING, 4" DOUBLE YELLOW LINE | |
| (H) EXISTING, 8" WHITE, 3' LONG, 3' SPACE | |

8/13/2020
10:51:56 AM



115 South 15th Street
Suite 200
Richmond, VA 23219
804.343.7100

**Bike Infrastructure /
Roadway Conversion Project**
Belmont Road
Richmond, Virginia

No.	Revision	Date	Apprd.

Designed by **SCN** Checked by **JLB**
Issued for **90% Construction Plan** Date **August 2020**

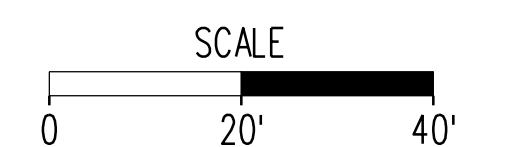

Drawing Title
Existing Conditions

PROJECT	SHEET NO.
	4

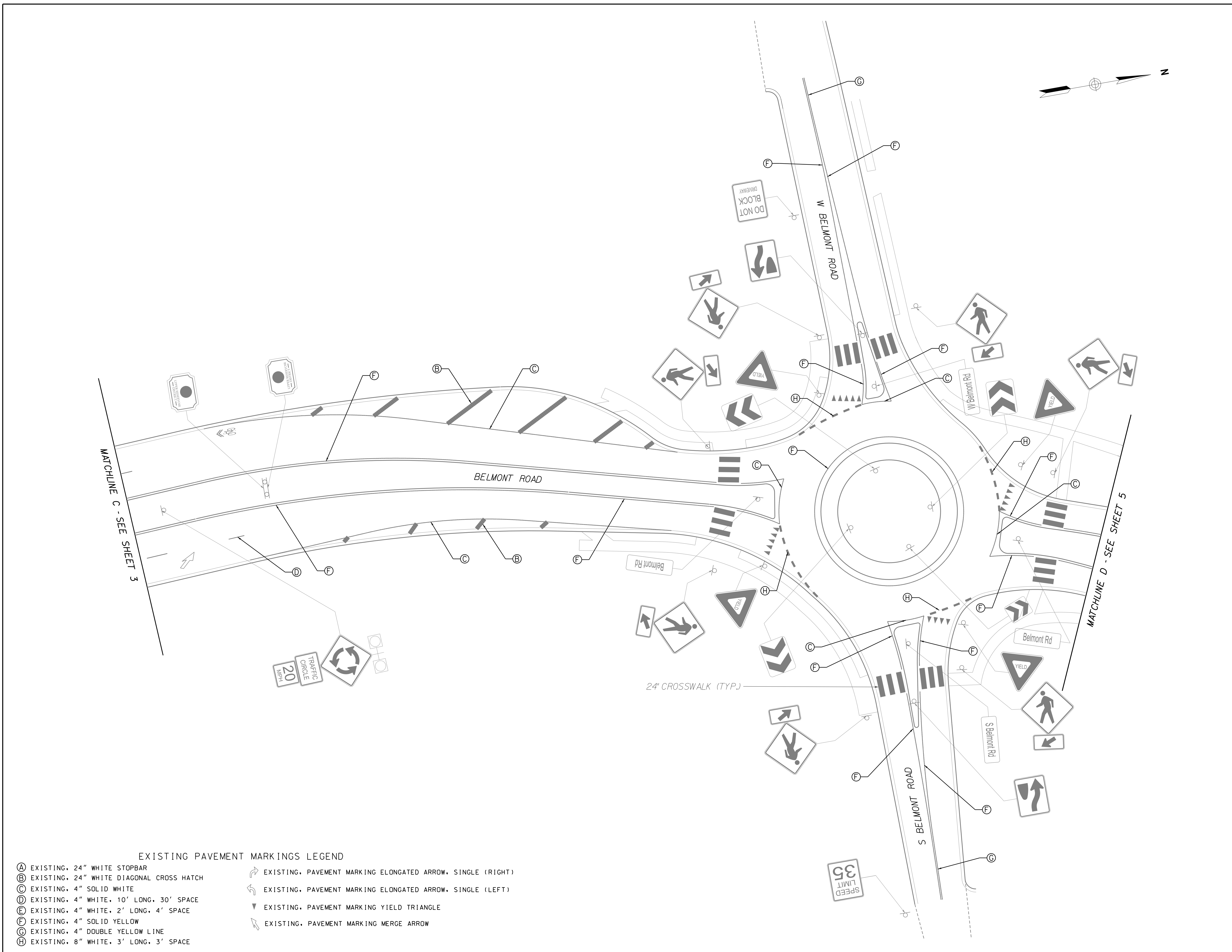

EXISTING PAVEMENT MARKINGS LEGEND

- | | |
|--|--|
| (A) EXISTING, 24" WHITE STOPBAR | ➤ EXISTING, PAVEMENT MARKING ELONGATED ARROW, SINGLE (RIGHT) |
| (B) EXISTING, 24" WHITE DIAGONAL CROSS HATCH | ➤ EXISTING, PAVEMENT MARKING ELONGATED ARROW, SINGLE (LEFT) |
| (C) EXISTING, 4" SOLID WHITE | ▼ EXISTING, PAVEMENT MARKING YIELD TRIANGLE |
| (D) EXISTING, 4" WHITE, 10' LONG, 30' SPACE | ➤ EXISTING, PAVEMENT MARKING MERGE ARROW |
| (E) EXISTING, 4" WHITE, 2' LONG, 4' SPACE | |
| (F) EXISTING, 4" SOLID YELLOW | |
| (G) EXISTING, 4" DOUBLE YELLOW LINE | |
| (H) EXISTING, 8" WHITE, 3' LONG, 3' SPACE | |

8/14/2020 3:28:45 PM



115 South 15th Street
Suite 200
Richmond, VA 23219
804.343.7100

**Bike Infrastructure /
Roadway Conversion Project**
Belmont Road
Richmond, Virginia

No.	Revision	Date	Appvd.

Designed by **SCN** Checked by **JLB**
Issued for **90% Construction Plan** Date: **August 2020**

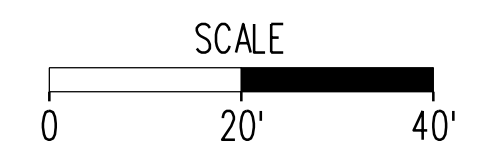

Drawing Title:
Existing Conditions

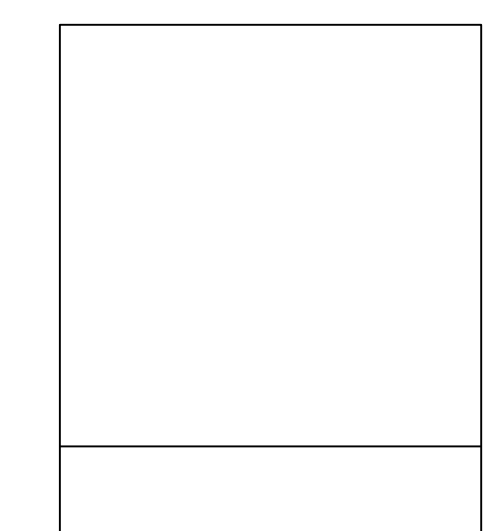

PROJECT SHEET NO.
5

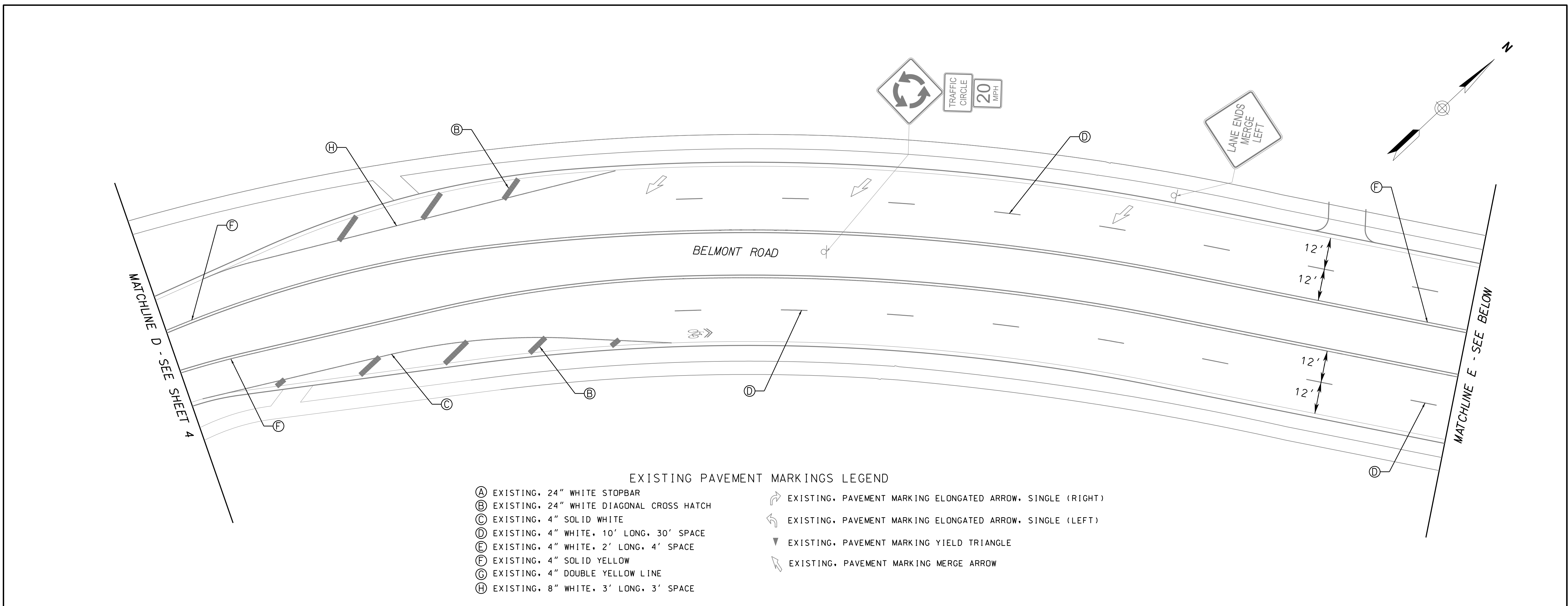

EXISTING PAVEMENT MARKINGS LEGEND

(A) EXISTING. 24" WHITE STOPBAR	↩ EXISTING. PAVEMENT MARKING ELONGATED ARROW, SINGLE (RIGHT)
(B) EXISTING. 24" WHITE DIAGONAL CROSS HATCH	↩ EXISTING. PAVEMENT MARKING ELONGATED ARROW, SINGLE (LEFT)
(C) EXISTING. 4" SOLID WHITE	▼ EXISTING. PAVEMENT MARKING YIELD TRIANGLE
(D) EXISTING. 4" WHITE, 10' LONG, 30' SPACE	↔ EXISTING. PAVEMENT MARKING MERGE ARROW
(E) EXISTING. 4" WHITE, 2' LONG, 4' SPACE	
(F) EXISTING. 4" SOLID YELLOW	
(G) EXISTING. 4" DOUBLE YELLOW LINE	
(H) EXISTING. 8" WHITE, 3' LONG, 3' SPACE	

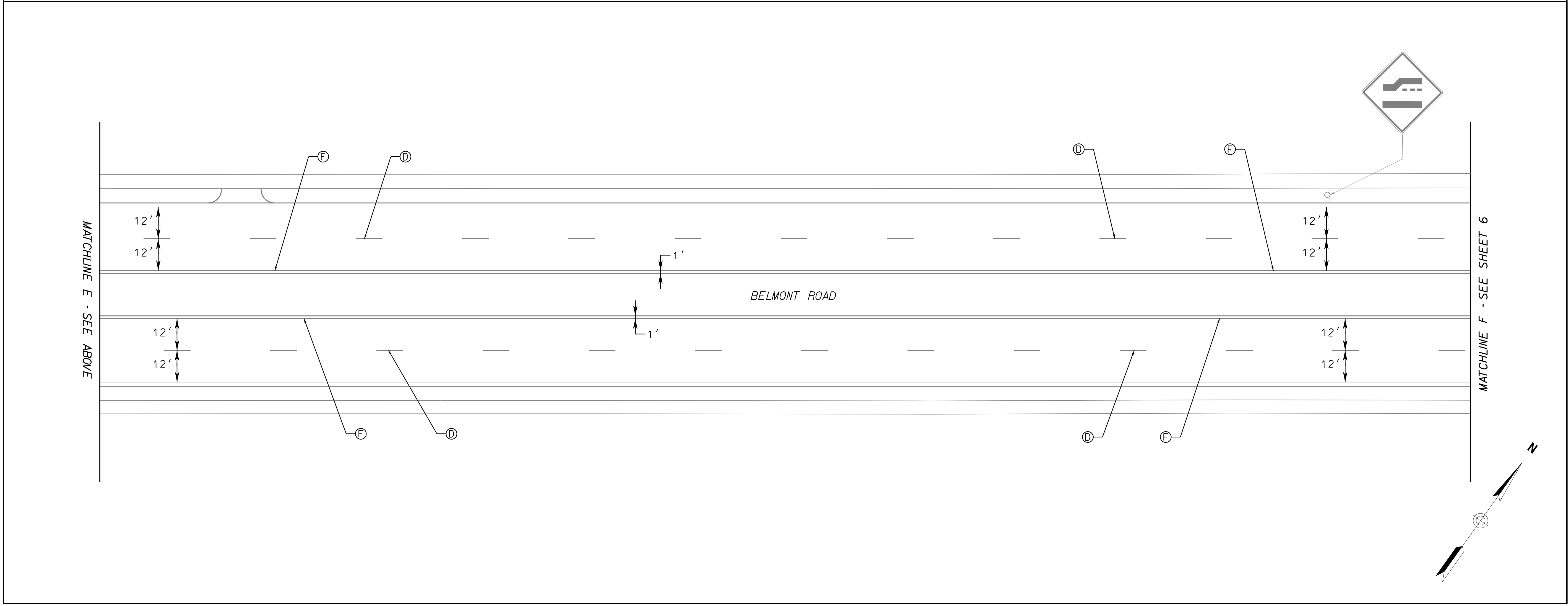



115 South 15th Street
Suite 200
Richmond, VA 23219
804.343.7100

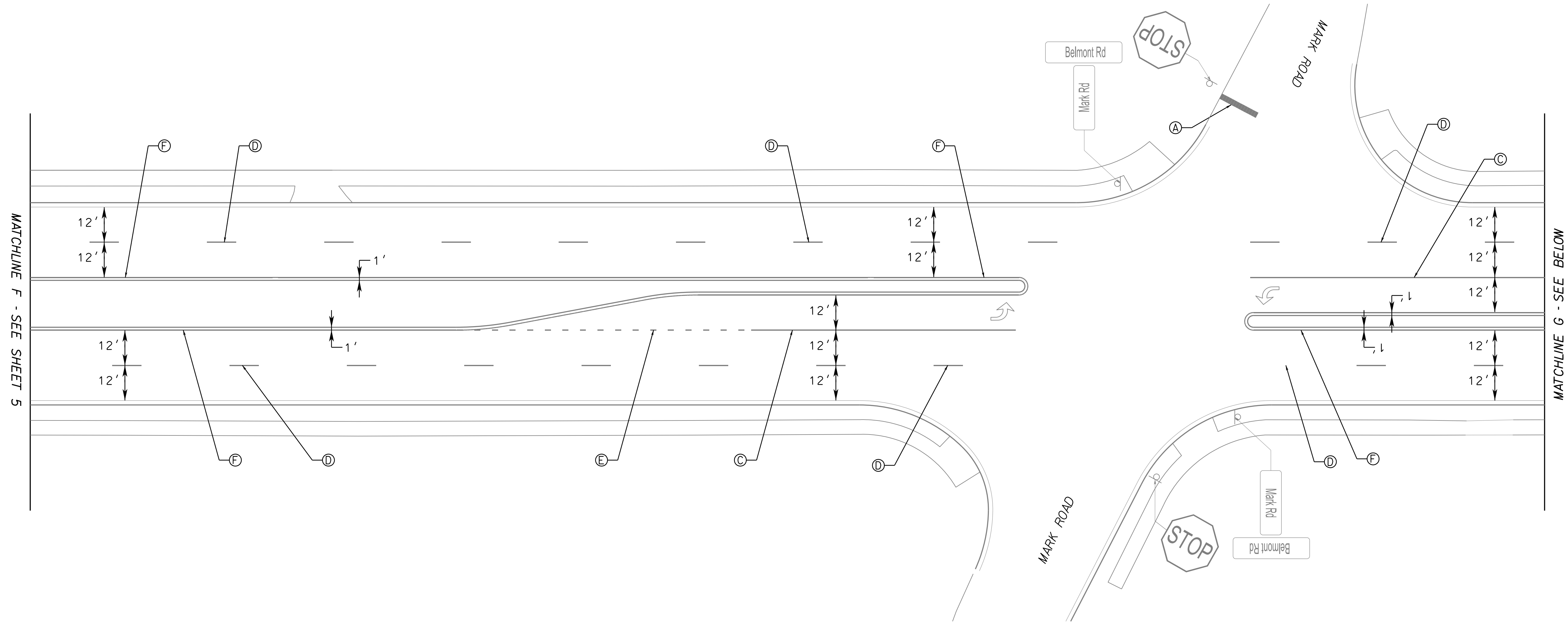

EXISTING PAVEMENT MARKINGS LEGEND

- (A) EXISTING, 24" WHITE STOPBAR
 - (B) EXISTING, 24" WHITE DIAGONAL CROSS HATCH
 - (C) EXISTING, 4" SOLID WHITE
 - (D) EXISTING, 4" WHITE, 10' LONG, 30' SPACE
 - (E) EXISTING, 4" WHITE, 2' LONG, 4' SPACE
 - (F) EXISTING, 4" SOLID YELLOW
 - (G) EXISTING, 4" DOUBLE YELLOW LINE
 - (H) EXISTING, 8" WHITE, 3' LONG, 3' SPACE
- ↪ EXISTING, PAVEMENT MARKING ELONGATED ARROW, SINGLE (RIGHT)
 - ↩ EXISTING, PAVEMENT MARKING ELONGATED ARROW, SINGLE (LEFT)
 - ▼ EXISTING, PAVEMENT MARKING YIELD TRIANGLE
 - ↗ EXISTING, PAVEMENT MARKING MERGE ARROW

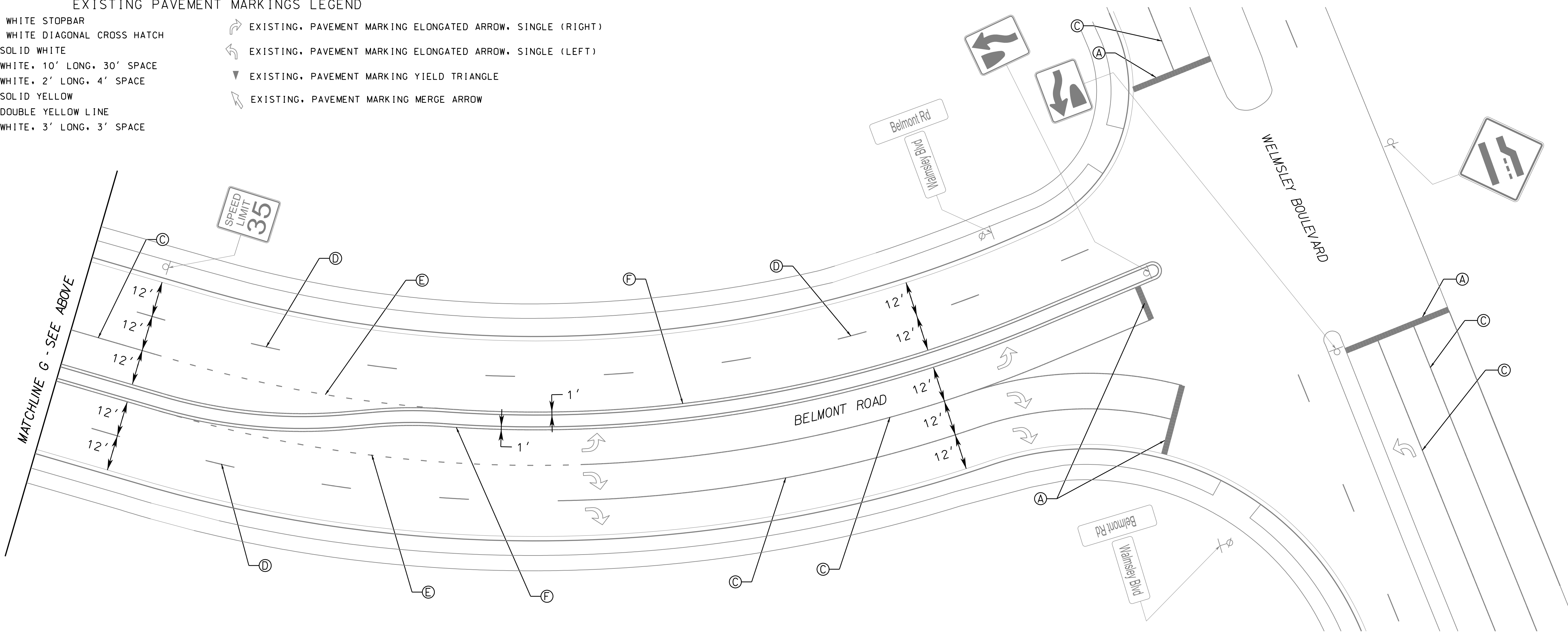

Bike Infrastructure / Roadway Conversion Project
Belmont Road
Richmond, Virginia

No.	Revision	Date	Appvd.

Designed by: **SCN** Checked by: **JLB**
Issued for: **90% Construction Plan** Date: **June 2020**

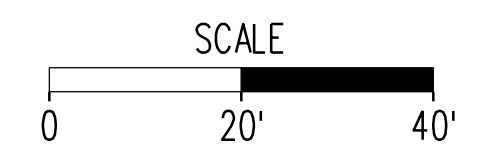

Existing Conditions

PROJECT	SHEET NO.
	6

8/14/2020
3:33:04 PM



115 South 15th Street
Suite 200
Richmond, VA 23219
804.343.7100

**Bike Infrastructure /
Roadway Conversion Project**
Belmont Road
Richmond, Virginia

No.	Revision	Date	Appvd.

Designed by: SCN Checked by: JLB
Issued for: 90% Construction Plan Date: August 2020

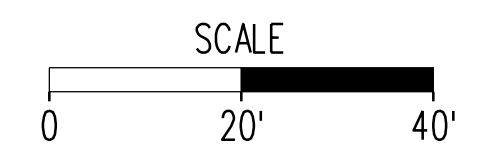

Drawing Title:
Proposed Conditions

PROJECT	SHEET NO.
	7

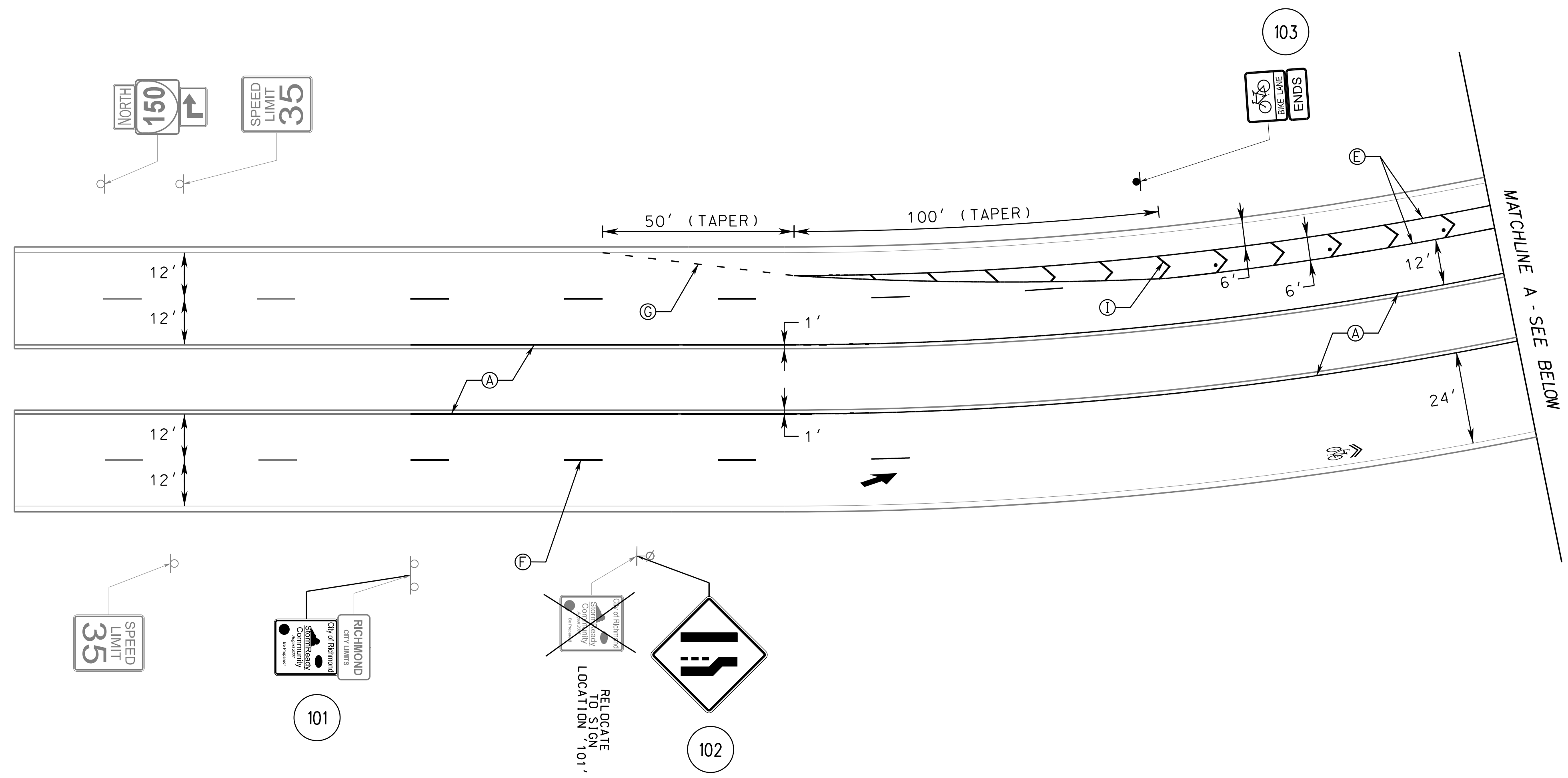

PROPOSED PAVEMENT MARKINGS LEGEND

- | | |
|--|--|
| (A) TYPE B, CLASS I, 4" SOLID YELLOW | (K) TYPE B, CLASS II, PREFORMED PAVEMENT MARKING ELONGATED ARROW, SINGLE (RIGHT) |
| (B) TYPE B, CLASS I, 24" SOLID WHITE | (L) TYPE B, CLASS II, PREFORMED PAVEMENT MARKING ELONGATED ARROW, SINGLE (LEFT) |
| (C) TYPE B, CLASS I, 24" CROSSBIKE, 3' SPACING | (M) TYPE B, CLASS II, PREFORMED PAVEMENT MARKING ELONGATED ARROW, SINGLE (MERGE) |
| (D) TYPE B, CLASS I, 24" CROSSWALK, 3' SPACING | (N) WHITE, FLEXIBLE POST DILINEATOR, 30' SPACING |
| (E) TYPE B, CLASS I, 4" SOLID WHITE | (O) TYPE B, CLASS I, PAVEMENT MARKING BICYCLE LANE ARROW (THRU) AND HELMETED BICYCLIST |
| (F) TYPE B, CLASS I, 4" WHITE, 10' LONG, 30' SPACE | (P) TYPE B, CLASS I, PAVEMENT MARKING SHARROW |
| (G) TYPE B, CLASS I, 4" WHITE, 2' LONG, 4' SPACE | |
| (H) TYPE B, CLASS I, 6" WHITE, 3' LONG, 3' SPACE | |
| (I) TYPE B, CLASS I, 6" WHITE CHEVRON, 15' SPACING | |
| (J) TYPE B, CLASS I, YIELD LINE, 3" SPACING | |

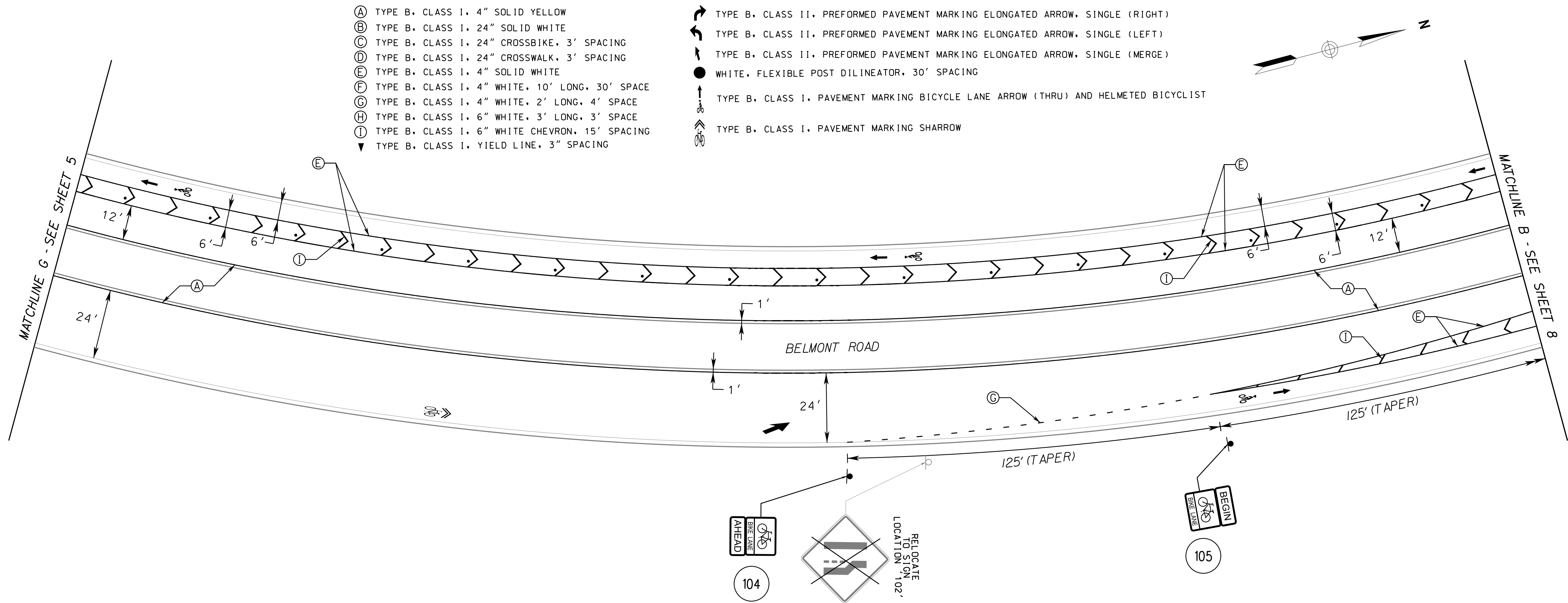

8/14/2020 4:59:30 PM



115 South 15th Street
Suite 200
Richmond, VA 23219
804.343.7100

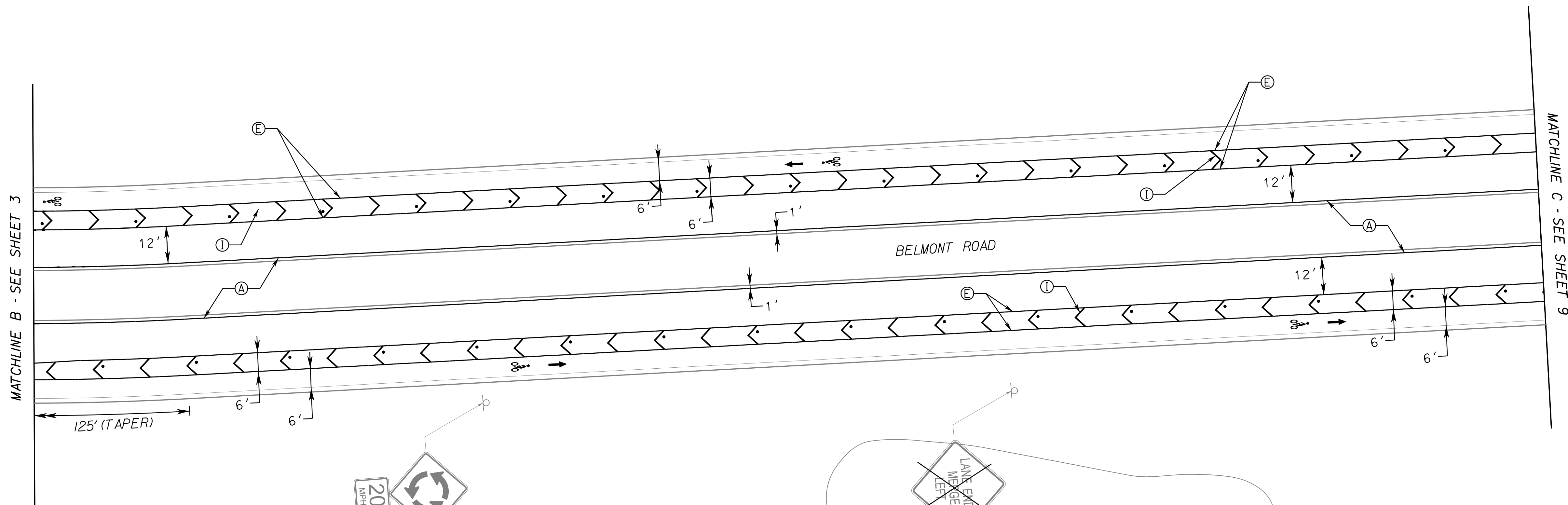
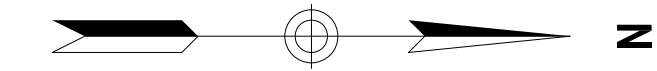

PROPOSED PAVEMENT MARKINGS LEGEND

- | | | |
|--|--|--|
| (A) TYPE B, CLASS I, 4" SOLID YELLOW | (H) TYPE B, CLASS I, 6" WHITE, 3' LONG, 3' SPACE | (K) TYPE B, CLASS I, PAVEMENT MARKING SHARROW |
| (B) TYPE B, CLASS I, 24" SOLID WHITE | (I) TYPE B, CLASS I, 6" WHITE CHEVRON, 15' SPACING | (L) TYPE B, CLASS II, PREFORMED PAVEMENT MARKING ELONGATED ARROW, SINGLE (LEFT) |
| (C) TYPE B, CLASS I, 24" CROSSBIKE, 3' SPACING | (J) TYPE B, CLASS I, YIELD LINE, 3" SPACING | (M) TYPE B, CLASS II, PREFORMED PAVEMENT MARKING ELONGATED ARROW, SINGLE (MERGE) |
| (D) TYPE B, CLASS I, 24" CROSSWALK, 3' SPACING | (N) TYPE B, CLASS II, PREFORMED PAVEMENT MARKING ELONGATED ARROW, SINGLE (RIGHT) | (O) TYPE B, CLASS I, PAVEMENT MARKING BICYCLE LANE ARROW (THRU) AND HELMETED BICYCLIST |
| (E) TYPE B, CLASS I, 4" SOLID WHITE | (P) TYPE B, CLASS II, PREFORMED PAVEMENT MARKING ELONGATED ARROW, SINGLE (MERGE) | (Q) WHITE, FLEXIBLE POST DILINEATOR, 30' SPACING |
| (F) TYPE B, CLASS I, 4" WHITE, 10' LONG, 30' SPACE | (R) TYPE B, CLASS II, PREFORMED PAVEMENT MARKING ELONGATED ARROW, SINGLE (MERGE) | |
| (G) TYPE B, CLASS I, 4" WHITE, 2' LONG, 4' SPACE | (S) TYPE B, CLASS I, PAVEMENT MARKING BICYCLE LANE ARROW (THRU) AND HELMETED BICYCLIST | |

Bike Infrastructure / Roadway Conversion Project
Belmont Road
Richmond, Virginia

No.	Revision	Date	Apprv.
Designed by	SCN	Checked by	JLB
Issued for	90% Construction Plan	Date	August 2020

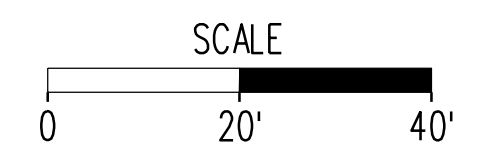

Drawing Title
Proposed Conditions

PROJECT	SHEET NO.
	8

B/1/17/2020
5:03:45 PM



115 South 15th Street
Suite 200
Richmond, VA 23219
804.343.7100

Bike Infrastructure / Roadway Conversion Project
Belmont Road
Richmond, Virginia

No.	Revision	Date	Appvd.

Designed by: **SCN** Checked by: **JLB**
Issued for: **90% Construction Plan** Date: **August 2020**

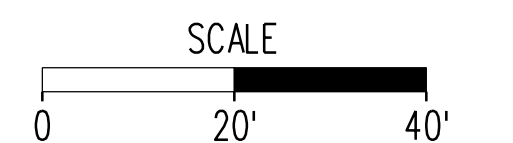

Proposed Conditions

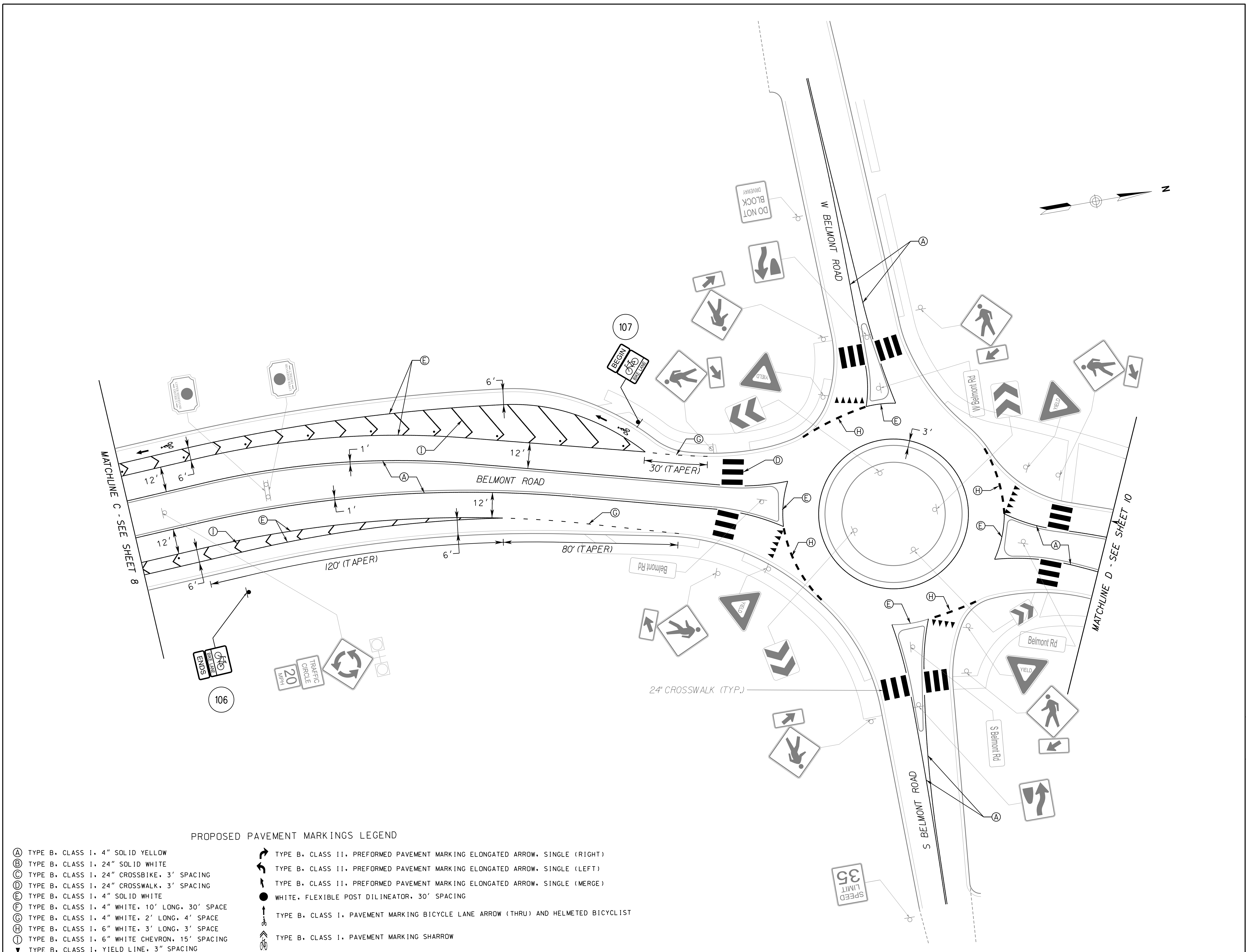

PROPOSED PAVEMENT MARKINGS LEGEND

- | | |
|--|--|
| (A) TYPE B, CLASS I, 4" SOLID YELLOW | (I) TYPE B, CLASS I, 6" WHITE CHEVRON, 15' SPACING |
| (B) TYPE B, CLASS I, 24" SOLID WHITE | (J) TYPE B, CLASS I, YIELD LINE, 3" SPACING |
| (C) TYPE B, CLASS I, 24" CROSSBIKE, 3' SPACING | |
| (D) TYPE B, CLASS I, 24" CROSSWALK, 3' SPACING | |
| (E) TYPE B, CLASS I, 4" SOLID WHITE | |
| (F) TYPE B, CLASS I, 4" WHITE, 10' LONG, 30' SPACE | |
| (G) TYPE B, CLASS I, 4" WHITE, 2' LONG, 4' SPACE | |
| (H) TYPE B, CLASS I, 6" WHITE, 3' LONG, 3' SPACE | |
| (L) TYPE B, CLASS I, 6" WHITE CHEVRON, 15' SPACING | |
| (V) TYPE B, CLASS I, YIELD LINE, 3" SPACING | |
| (A) TYPE B, CLASS II, PREFORMED PAVEMENT MARKING ELONGATED ARROW, SINGLE (RIGHT) | |
| (B) TYPE B, CLASS II, PREFORMED PAVEMENT MARKING ELONGATED ARROW, SINGLE (LEFT) | |
| (C) TYPE B, CLASS II, PREFORMED PAVEMENT MARKING ELONGATED ARROW, SINGLE (MERGE) | |
| (D) WHITE, FLEXIBLE POST DILINEATOR, 30' SPACING | |
| (E) TYPE B, CLASS I, PAVEMENT MARKING BICYCLE LANE ARROW (THRU) AND HELMETED BICYCLIST | |
| (F) TYPE B, CLASS I, PAVEMENT MARKING SHARROW | |

8/14/2020 4:24:23 PM



115 South 15th Street
Suite 200
Richmond, VA 23219
804.343.7100

**Bike Infrastructure /
Roadway Conversion Project**
Belmont Road
Richmond, Virginia

No.	Revision	Date	Appvd.

Designed by: **SCN** Checked by: **JLB**
Issued for: **90% Construction Plan** Date: **August 2020**

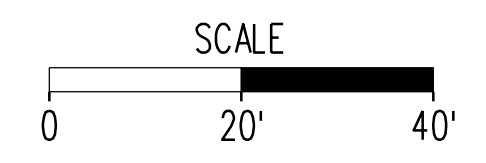

Drawing Title:
Proposed Conditions

PROJECT	SHEET NO.
	10

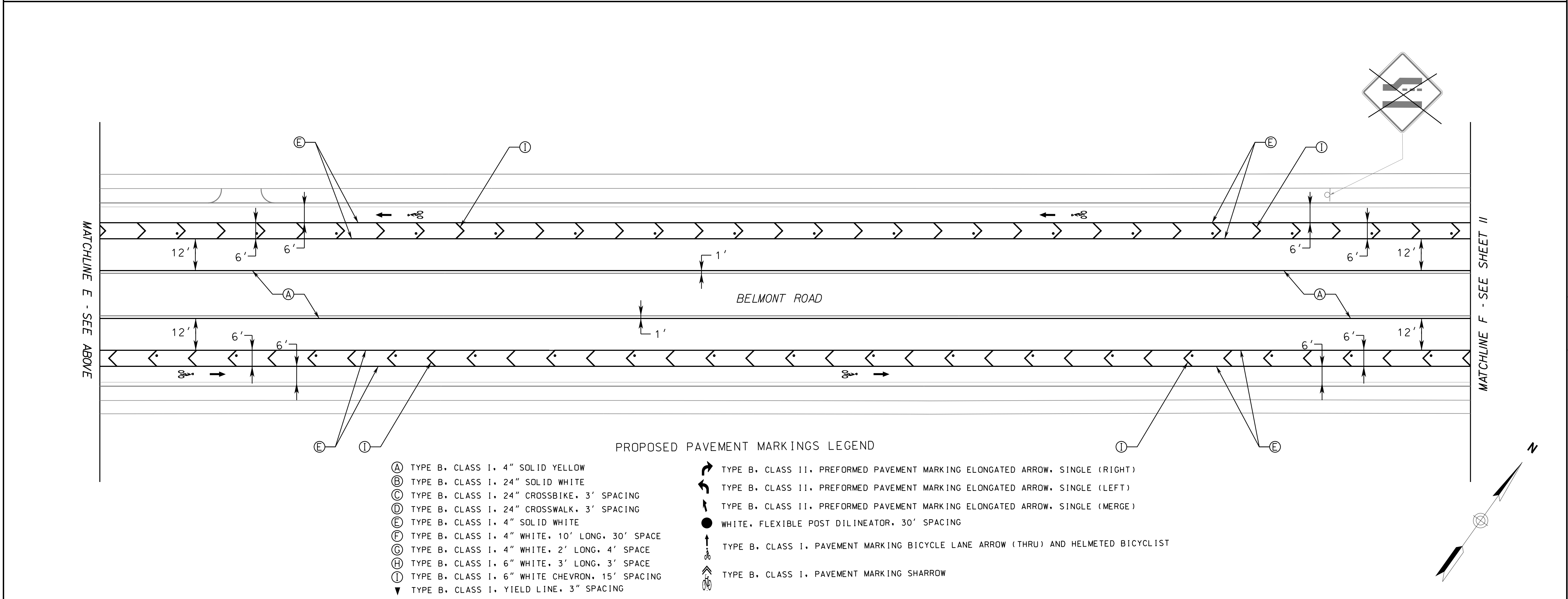
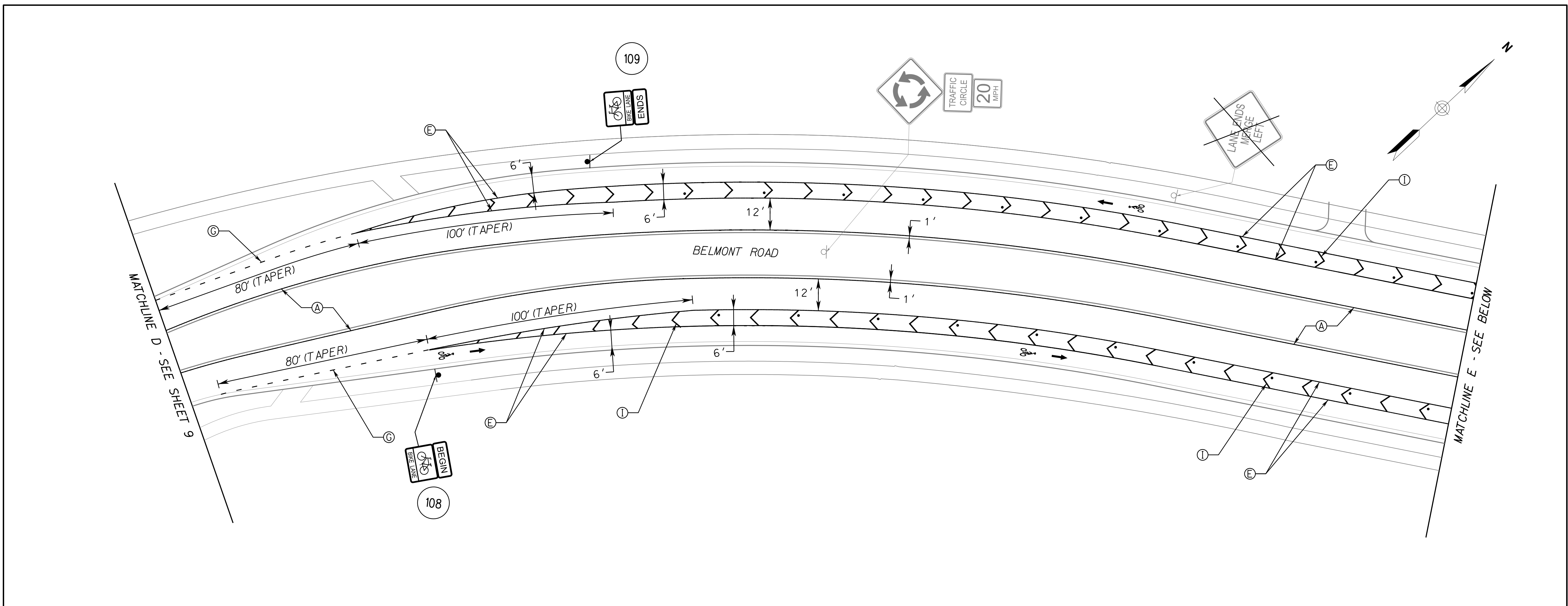

- PROPOSED PAVEMENT MARKINGS LEGEND**
- (A) TYPE B, CLASS I, 4" SOLID YELLOW
 - (B) TYPE B, CLASS I, 24" SOLID WHITE
 - (C) TYPE B, CLASS I, 24" CROSSBIKE, 3' SPACING
 - (D) TYPE B, CLASS I, 24" CROSSWALK, 3' SPACING
 - (E) TYPE B, CLASS I, 4" SOLID WHITE
 - (F) TYPE B, CLASS I, 4" WHITE, 10' LONG, 30' SPACE
 - (G) TYPE B, CLASS I, 4" WHITE, 2' LONG, 4' SPACE
 - (H) TYPE B, CLASS I, 6" WHITE, 3' LONG, 3' SPACE
 - (I) TYPE B, CLASS I, 6" WHITE CHEVRON, 15' SPACING
 - ▼ TYPE B, CLASS I, YIELD LINE, 3" SPACING
 - ➡ TYPE B, CLASS II, PREFORMED PAVEMENT MARKING ELONGATED ARROW, SINGLE (RIGHT)
 - ➡ TYPE B, CLASS II, PREFORMED PAVEMENT MARKING ELONGATED ARROW, SINGLE (LEFT)
 - ➡ TYPE B, CLASS II, PREFORMED PAVEMENT MARKING ELONGATED ARROW, SINGLE (MERGE)
 - WHITE, FLEXIBLE POST DILINEATOR, 30' SPACING
 - ➡ TYPE B, CLASS I, PAVEMENT MARKING BICYCLE LANE ARROW (THRU) AND HELMETED BICYCLIST
 - ➡ TYPE B, CLASS I, PAVEMENT MARKING SHARROW

8/14/2020
5:07:34 PM



115 South 15th Street
Suite 200
Richmond, VA 23219
804.343.7100

Bike Infrastructure / Roadway Conversion Project Belmont Road Richmond, Virginia

No.	Revision	Date	Appr.

Designed by: SCN Checked by: JLB
Issued for: 90% Construction Plan Date: August 2020

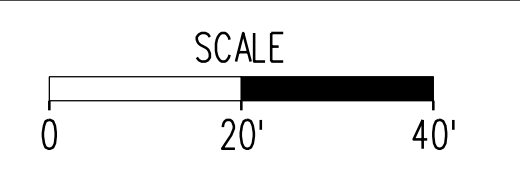

Drawing Title:
Proposed Conditions

PROJECT	SHEET NO.
	//

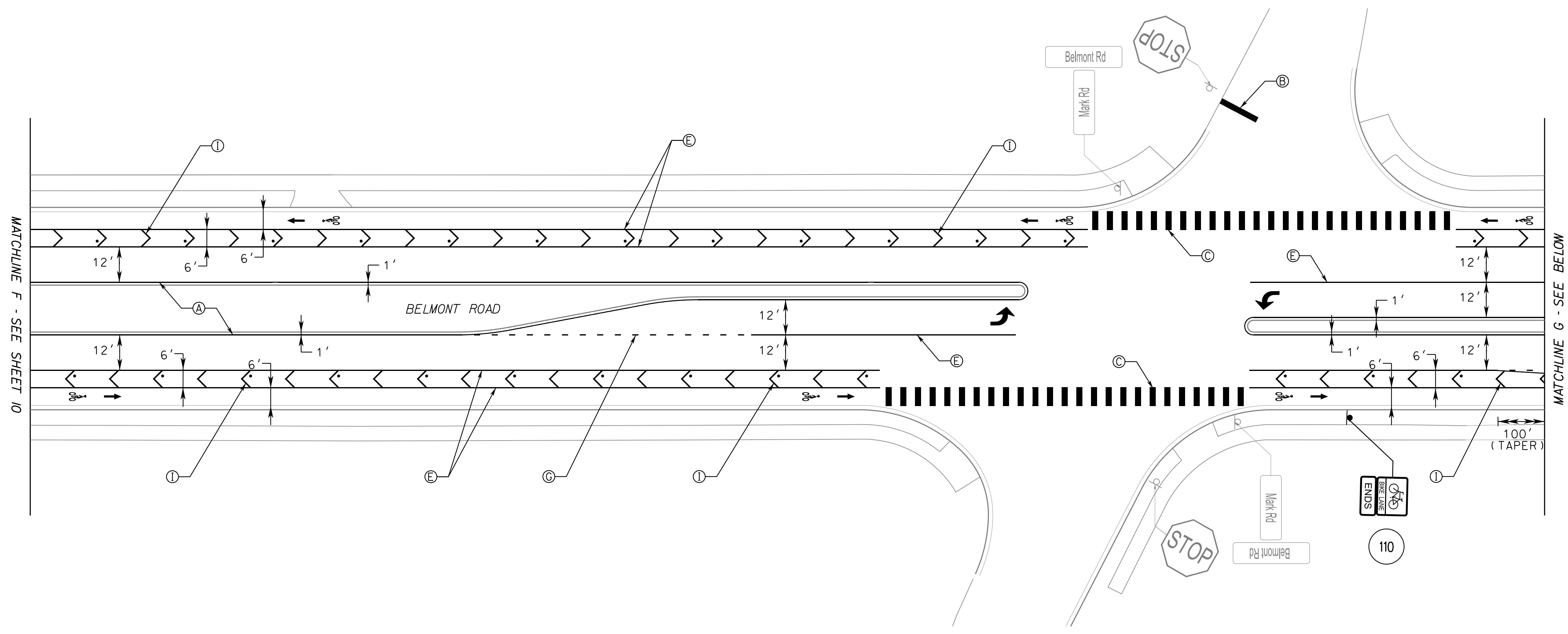

PROPOSED PAVEMENT MARKINGS LEGEND

- (A) TYPE B, CLASS 1, 4" SOLID YELLOW
- (B) TYPE B, CLASS 1, 24" SOLID WHITE
- (C) TYPE B, CLASS 1, 24" CROSSBIKE, 3' SPACING
- (D) TYPE B, CLASS 1, 24" CROSSWALK, 3' SPACING
- (E) TYPE B, CLASS 1, 4" SOLID WHITE
- (F) TYPE B, CLASS 1, 4" WHITE, 10' LONG, 30' SPACE
- (G) TYPE B, CLASS 1, 4" WHITE, 2' LONG, 4' SPACE
- (H) TYPE B, CLASS 1, 6" WHITE, 3' LONG, 3' SPACE
- (I) TYPE B, CLASS 1, 6" WHITE CHEVRON, 15' SPACING
- ▼ TYPE B, CLASS 1, YIELD LINE, 3" SPACING
- TYPE B, CLASS 11, PREFORMED PAVEMENT MARKING ELONGATED ARROW, SINGLE (RIGHT)
- TYPE B, CLASS 11, PREFORMED PAVEMENT MARKING ELONGATED ARROW, SINGLE (LEFT)
- TYPE B, CLASS 11, PREFORMED PAVEMENT MARKING ELONGATED ARROW, SINGLE (MERGE)
- WHITE, FLEXIBLE POST DILINEATOR, 30' SPACING
- TYPE B, CLASS 1, PAVEMENT MARKING BICYCLE LANE ARROW (THRU) AND HELMETED BICYCLIST
- TYPE B, CLASS 1, PAVEMENT MARKING SHARROW

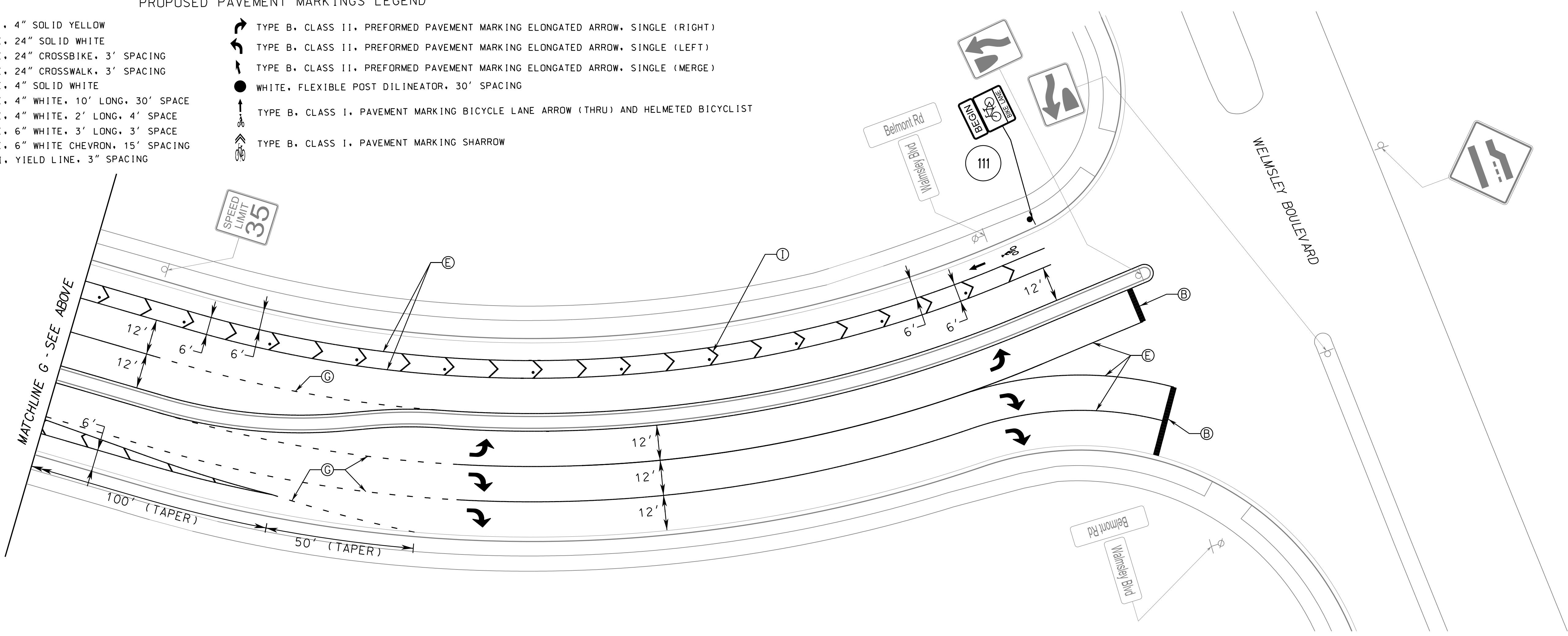

8/14/2020
4:49:01 PM